

LISTA MOTORES PELET 600 HP FINCA MOSQUERA

FINCA MOSQUERA- LISTA DE MOTORES PELET N° 5 - LLEGO EN JUNIO 9 2022

3F- 460V- 50 Ka a 460V

Interruptores marca LSIS
 Guardamotores marca Eaton
 Contactores Marca Eaton
 VV marca INVT
 SS Marca Eaton
 Reactancias marca INVT

Moto	Proyecto	Descripcion	Cant.	Kw	RPM	HP	Amps Nom	FS 1.15	Kva	Tipo de arranque	Int	GM	Contacto	VFD	SS	Reatancia	FS-Redu	RPM	Transmision	Ref de Moto			
M1	22-202-6	Transportador Transversal de Cadena 8,7m	1	3		4.08	6,9	7,9	6,3	D	NA	6,3--10	PKZO-10	DILM17	NA	NA	NA	1,5	90	Piñon-cadena	Eje solido		
M2	22-202-7	Transportador Longitudinal Puente de Cadena 31m	1	9,2		12,51	18,4	21,2	16,8	D	NA	20--25	PKZO-25	DILM32	NA	NA	NA	1,5	90	Piñon-cadena	Eje solido		
M3	22-202-8	Transportador debaixo Puente de Cadena 4m	1	1,1		1,50	3	3,5	2,7	D	NA	2,5--4	PKZO-4	DILM12	NA	NA	NA	1,5	90	Piñon-cadena	Eje solido		
M4	22-202-9	Elevador de Cangilones Tolvas Granel 19,8m	1	5,5		7,48	11	12,7	10,1	D	NA	10--16	PKZO-16	DILM17	NA	NA	NA	1,8	90	Piñon-cadena	Eje solido		
M5	22-202-10	Transportador de cadena Recibe elevador 3m	1	1,1		1,50	3	3,5	2,7	D	NA	2,5--4	PKZO-4	DILM12	NA	NA	NA	1,5	90	Piñon-cadena	Eje solido		
M6	22-202-11	Transportador de cadena Llenado de Tolvas Granel 8	1	3		4,08	6,9	7,9	6,3	D	NA	6,3--10	PKZO-10	DILM17	NA	NA	NA	1,5	90	Piñon-cadena	Eje solido		
M7	22-249-2	Fondo Vivo N° 1	1	3		4,08	6,9	7,9	6,3	D	NA	6,3--10	PKZO-10	DILM17	NA	NA	NA	1,6	30	Directo	Eje Hueco		
M8		Fondo Vivo N° 2	1	3		4,08	6,9	7,9	6,3	D	NA	6,3--10	PKZO-10	DILM17	NA	NA	NA	1,6		Directo			
M9		Fondo Vivo N° 3	1	3		4,08	6,9	7,9	6,3	D	NA	6,3--10	PKZO-10	DILM17	NA	NA	NA	1,6		Directo			
M10		Fondo Vivo N° 4	1	3		4,08	6,9	7,9	6,3	D	NA	6,3--10	PKZO-10	DILM17	NA	NA	NA	1,6		Directo			
M11		Fondo Vivo N° 5	1	3		4,08	6,9	7,9	6,3	D	NA	6,3--10	PKZO-10	DILM17	NA	NA	NA	1,6		Directo			
M12		Fondo Vivo N° 6	1	3		4,08	6,9	7,9	6,3	D	NA	6,3--10	PKZO-10	DILM17	NA	NA	NA	1,6		Directo			
M13		Alimentador Peletizadora CPM FDAINF12	1	2,2		2,99	4,8	5,5	4,4	VV	NA	4--6,3	PKZO-6,3	NA	GD350-004G-4	NA	ACL2-004-4			Directo	Eje Hueco		
M14		Acondicionador CPM CA30LTC16	1	30		40,80	52	59,8	47,6	VV	3P-100	NA	NA	NA	GD350-037G-4	NA	ACL2-037G-4			Directo	Eje Hueco		
M15		Pelletizadora CPM PM7936-14	1	440	1800	###	714	821,1	653,4	SS	3P-1200	NA	NA	NA	NA	S811+V85	NA				Caja Reductor	Eje solido	
M16		Esclusa alimentadora Enfriador CPM	1	0,25		0,34	0,8	0,9	0,7	D	NA	1--1,6	PKZO-1,6	DILM7	NA	NA	NA						
M17		Enfriador Contra Flujo CPM CCR2838 Unidad Hidra	1	2,2		2,99	4,8	5,5	4,4	D	NA	4--6,3	PKZO-6,3	DILM15	NA	NA	NA						
M18		Ventilador NYB574LS	1	92	1800	###	156	179,4	142,8	VV	3P-250	NA	NA	NA	GD350-110G-4	NA	ACL2-110-4					Polea Correa	Eje solido
M19		Transportador de cadena evacuacion Enfriador 6,2m	1	3		4,08	6,9	7,9	6,3	D	NA	6,3--10	PKZO-10	DILM17	NA	NA	NA	1,5	90	Piñon Cadena	Eje Solido		
M20		Elevador de Cangilones PT 23,4m	1	7,5		10,20	14	16,1	12,8	D	NA	10--16	PKZO-16	DILM32	NA	NA	NA	1,8	90	Piñon cadena	Eje Solido		
M21		Transportador Alimentador Zaranda 3,2m	1	1,1		1,50	3	3,5	2,7	D	NA	2,5--4	PKZO-4	DILM12	NA	NA	NA	1,5	90	Piñon Cadena	Eje solido		
M22		Zaranda Rotex 205771E	1	7,5		10,20	14	16,1	12,8	D	NA	10--16	PKZO-16	DILM32	NA	NA	NA	1,5		Caja Reductor	Eje Solido		
M23		Bomba Inyeccion Aceite Viking	1	1,1		1,50	3	3,5	2,7	D	NA	2,5--4	PKZO-4	DILM12	NA	NA	NA	1,3	400	directa	Eje solido		
M24	22-250-4	Elevador Cangilones Post engrase 10,5m	1	4		5,44	8,6	9,9	7,9	D	NA	6,3--10	PKZO-10	DILM17	NA	NA	NA	1,8	90	Piñon Cadena	Eje Solido		
M25	22-250-5	Transportador PT Transversal Sobre Tolvas ensaque	1	4		5,44	8,6	9,9	7,9	D	NA	6,3--10	PKZO-10	DILM17	NA	NA	NA	1,5	90	Piñon Cadena			
M26	22-250-6	Transportador PT Longitudinal Sobre Tolvas ensaque	1	1,5		2,04	3,4	3,9	3,1	D	NA	2,5--4	PKZO-4	DILM12	NA	NA	NA	1,5	90	Piñon Cadena			
M27		Esclusa Filtro Ciclon Metalteco	1	0,75		1,02	2,1	2,4	1,9	D	NA	1,6--2,5	PKZO-2,5	DILM12	NA	NA	NA	1,5					
M28		Transportador sinfin de Devolucion Finos 9,8m	1	4		5,44	8,6	9,9	7,9	D	NA	6,3--10	PKZO-10	DILM15	NA	NA	NA	1,5	45	Piñon cadena	Eje Solido		
M29		Reserva	1			5,00	7,6	8,7	7,0														

29 642 878 1.103 1.268 1.009
 DEMANDA 0,8 882 1.015 807

389
 311,04

Interruptor General 3P-1200

CAPACITORES DISPROEL 3F-480V KVAR 161

PASO	Kvar	Altura	Diam	Amps	Int	Contacto
1	5	170	75	6	3P-15	MC-22
2	10	230	85	12	3P-30	MC-22
3	30	360	95	36	3P-60	MC-65
4	30	360	95	36	3P-60	MC-65
5	30	360	95	36	3P-60	MC-65
6	30	360	95	36	3P-60	MC-65
7	30	360	95	36	3P-60	MC-65

LISTA MOTORES PELET 600 HP FINCA MOSQUERA

165

Accesorios Auto Lubricador 1
 Filtro Ciclon Disparos Neumaticos Metalteco 1

SUMINISTRADOS POR OTROS

22-250-3	Banda Pesadora Alimentadora Engrasador	1	0,75	1,02	2,1	2,4	1,9	D	NA				NA	NA	NA	1,7	31	Directo	Eje Hueco
22-250-3	Engrasador adicionador de Aceite	1	1,5	2,04	3,4	3,9	3,1	D	NA				NA	NA	NA	1,15	1200	Polea correa	Eje Solido
22-250-3	Homogenizador post engrase	1	3	4,08	6,9	7,9	6,3	D	NA				NA	NA	NA	1,5	65	Piñon Cadena	Eje solido

TRANSFORMADOR PARA CONTROL

TRANSFORMADOR PARA CONTROL

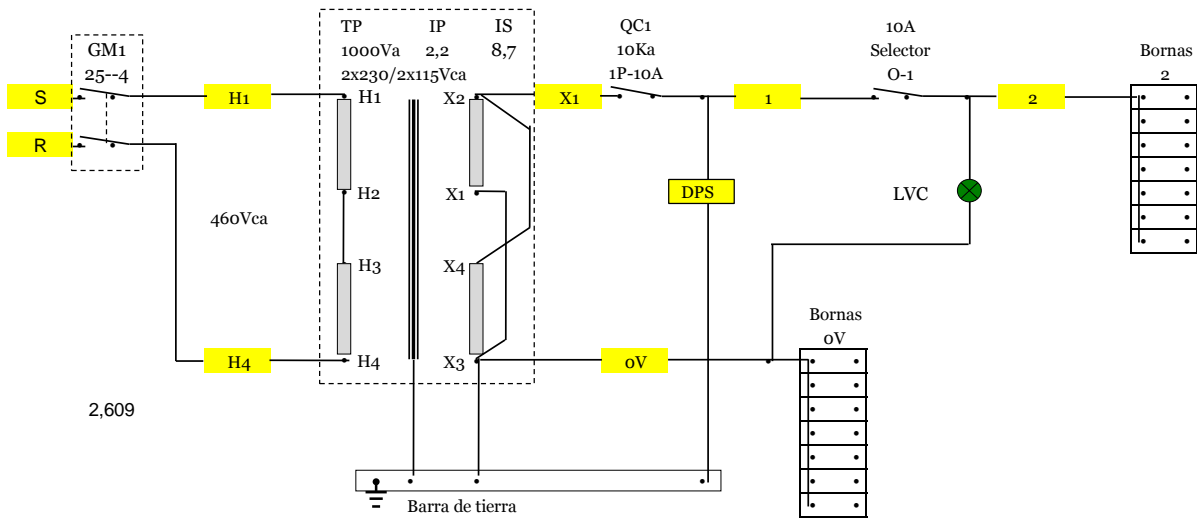

Minibreakers marca GEWISS (GW92)

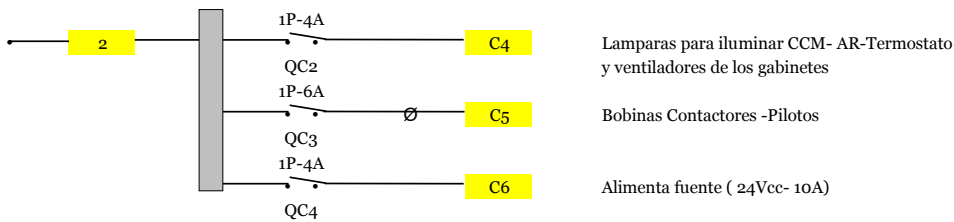

- TP Transformador para control 1000 Va - Voltaje primario (2 devanados cada uno para 230 Vca)
Voltaje secundario (2 devanados cada uno para 115 Vca)
Debe llevar pantalla electrostática para conectar a tierra
- DPS LEVINTON 5280-W
- LVC Luz verde - Indica que hay voltaje para control
- O-1 Selector 10A , instalado en la puerta del CCM - Habilita el control.

CONTROL DE TEMPERATURA

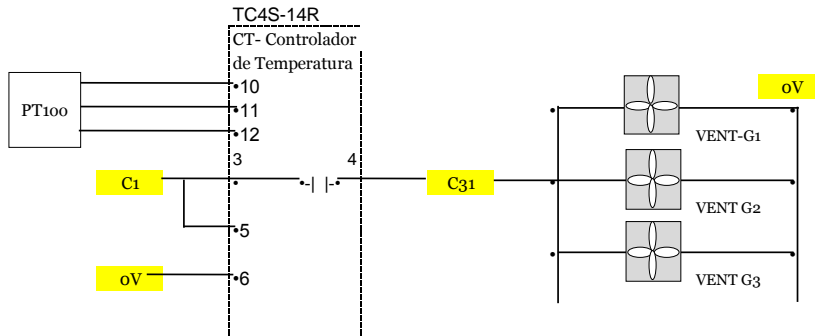

TRANSFORMADOR PARA CONTROL

ILUMINACION DE GABINETES

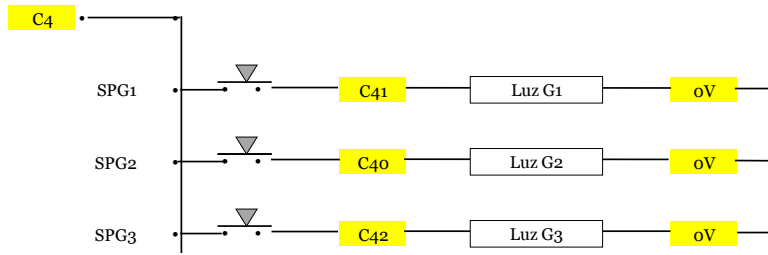

SPG 2/3 Suiches en las puertas - energizan las lámparas para iluminar el gabinete
Luz G 2/3 Luz fluorescente

FUENTE CON SALIDA DE 24 Vcc - 30 Acc

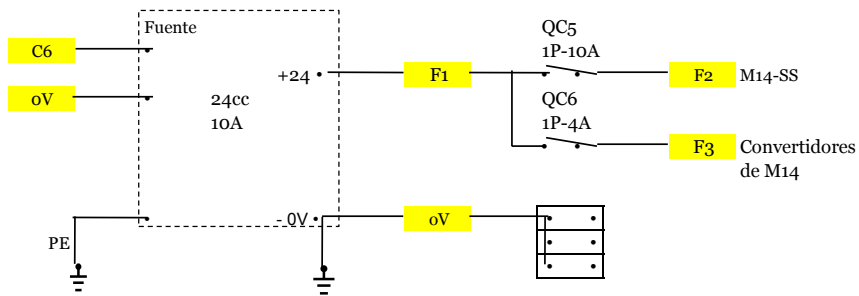

TRANSFORMADOR PARA CONTROL

ANALIZADOR DE REDES Y CONTROLADOR DE FACTOR DE POTENCIA

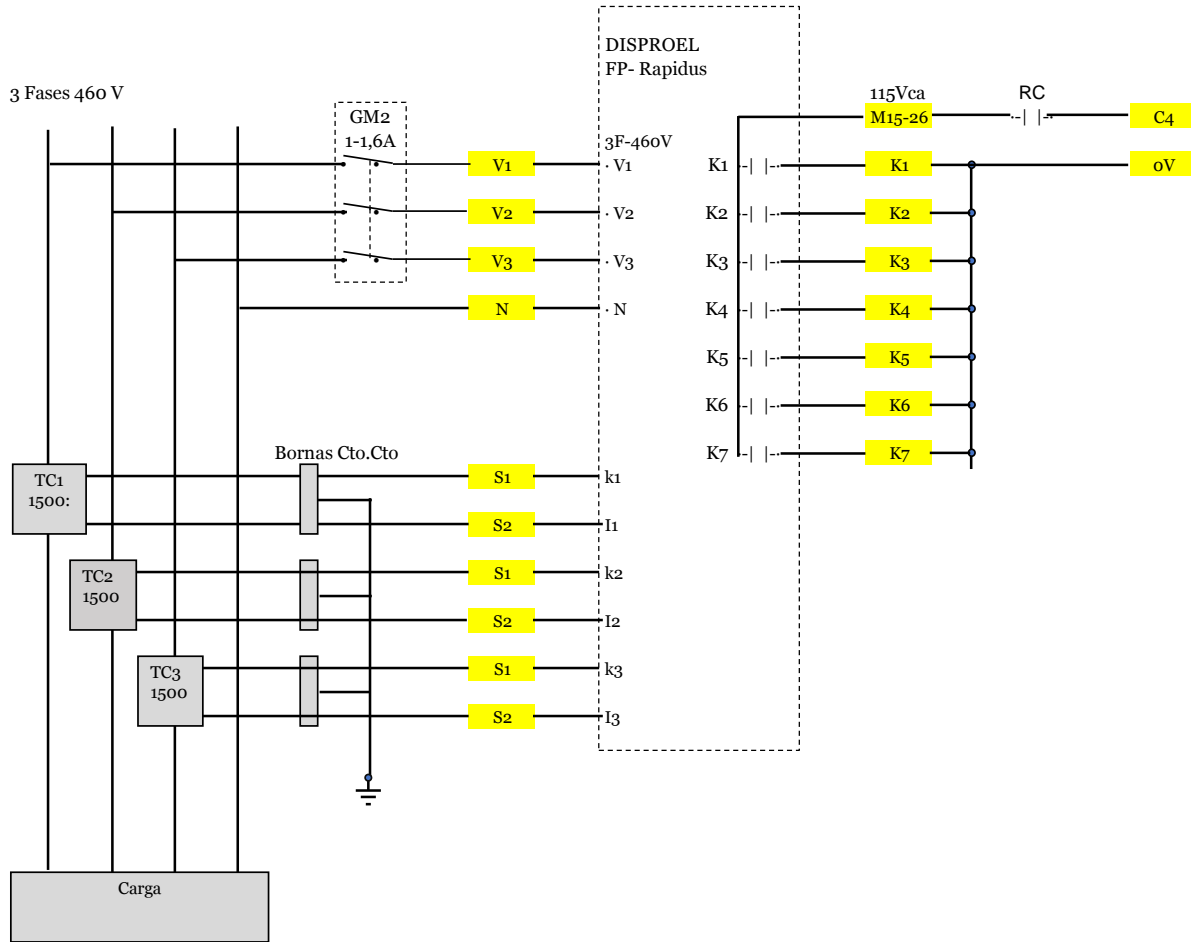

El CFP Rapidus (DISPROEL) en un controlador de factor de potencia que a su vez es analizador de redes

UNIFILAR CCM-PELET 600 HP FINCA MOSQUERA

UNIFILAR PELET CPM -600 HP

Fases	Voltios	Hz	Ka		
3	460	60	50		

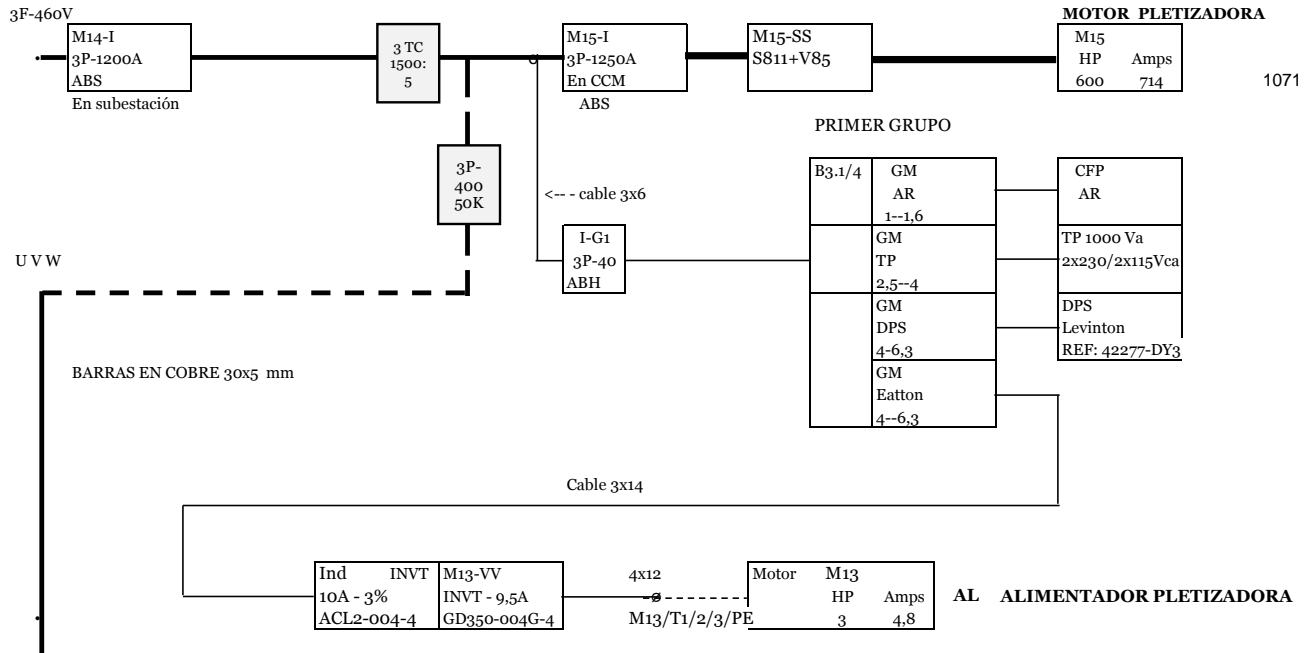

B3.1/4		BK25	
GM 1	GM 2	GM 3	GM 4

92,4	27,72
45	13,5
	54

UNIFILAR CCM-PELET 600 HP FINCA MOSQUERA

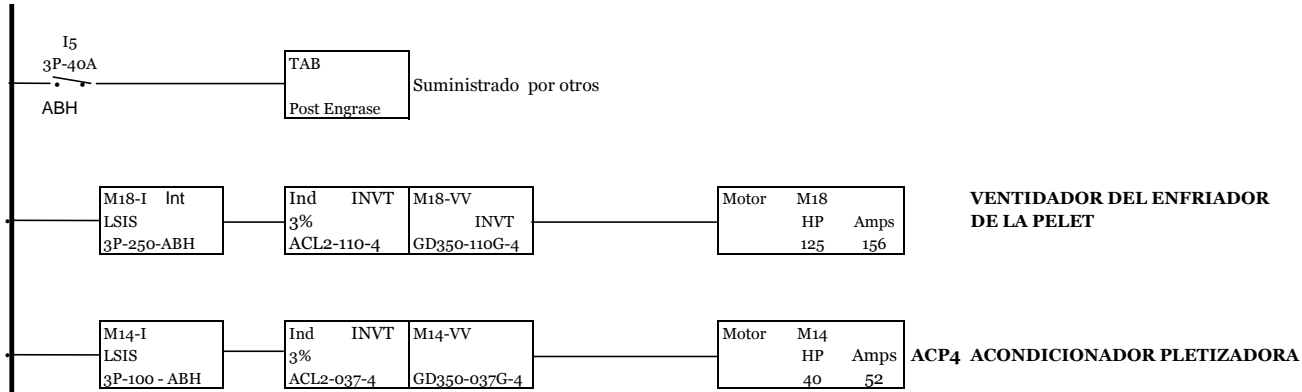

SEGUNDO GRUPO

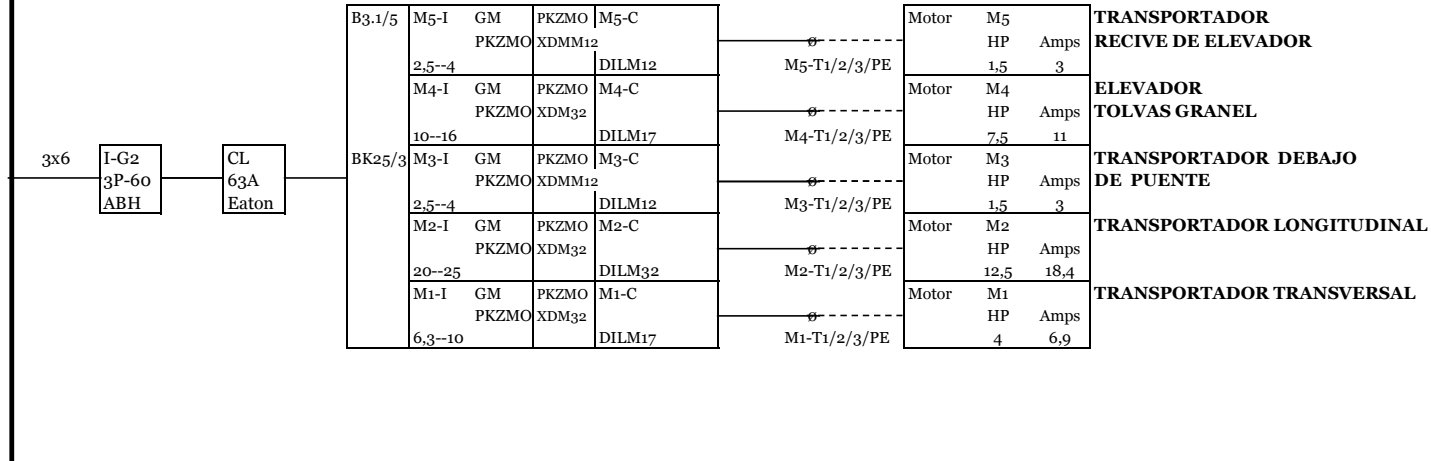

B3.1/5	BK2			
GM 6,3/10	GM 20/25	GM 2,5/4	GM 10/16	GM 2,5/4
M1-C DILM 17	M2-C DIL M32	M3-C DIL	M4-C DIL M17	M5-C DIL

UNIFILAR CCM-PELET 600 HP FINCA MOSQUERA

UVW

UVW

TERCER GRUPO

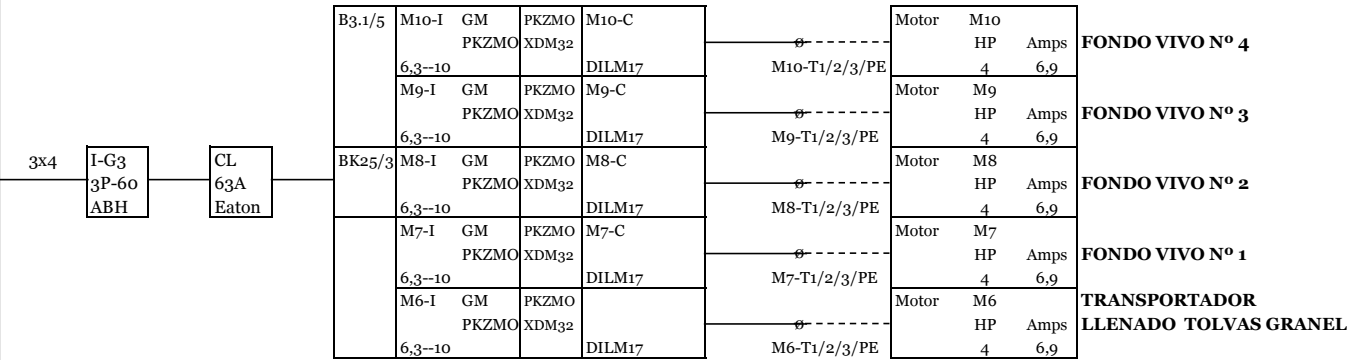

B3.1/5		BK25		
GM M6-I 6,3/10	GM M7-I 6,3/10	GM M8-I 6,3/10	GM M9-I 6,3/10	GM M10-I 6,3/10
XDM3	XDM3	XDM32	XDM32	XDM3
M6-C DIL M17	M7-C DIL M17	M8-C DIL M17	M9-C DIL M17	M10-C DIL M17

CUARTO GRUPO

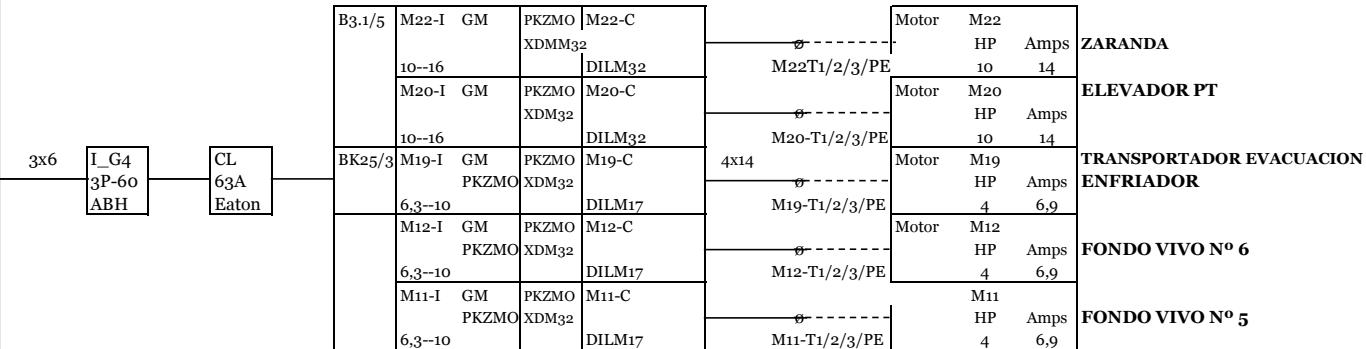

B3.1/5		BK25		
GM M11-I 6,3/10	GM M12-I 6,3/10	GM M19-I 6,3/10	GM M20-I PKZMO 10/16	GM M22-I PKZMO 10/16
XDM3	XDM3	XDM3	XDM32	XDM3
M11-C DIL M17	M12-C DIL M17	M19-C DIL M17	M20-C DIL M32	M22-C DIL M32

UNIFILAR CCM-PELET 600 HP FINCA MOSQUERA

QUINTO GRUPO

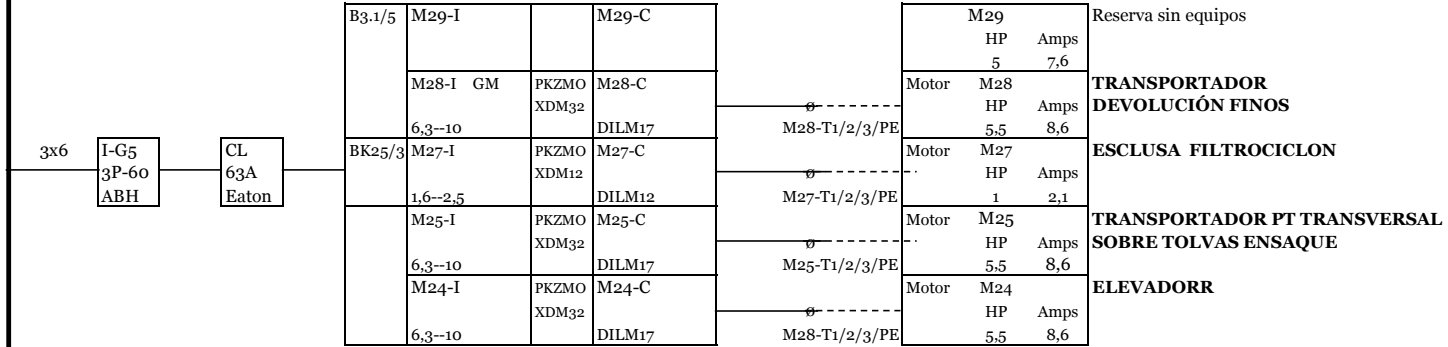

B3.1/5		BK2		
GM M23-I PKZMO 2,5/4	GM M24 -I PKZMO 6,3/10	GM 25-I PKZMO 6,3/10	GM M28 -I PKZMO 6,3/10	GM M24 -I PKZMO R
XDM32	XDM3	XDM3	XDM1	
M23-C	M24-C	M25-C	M8-I	M24-C R
DIL M12	DIL M17	DIL M17	DIL M17	DIL M15

<---PKZMO-XI

SEXTO GRUPO

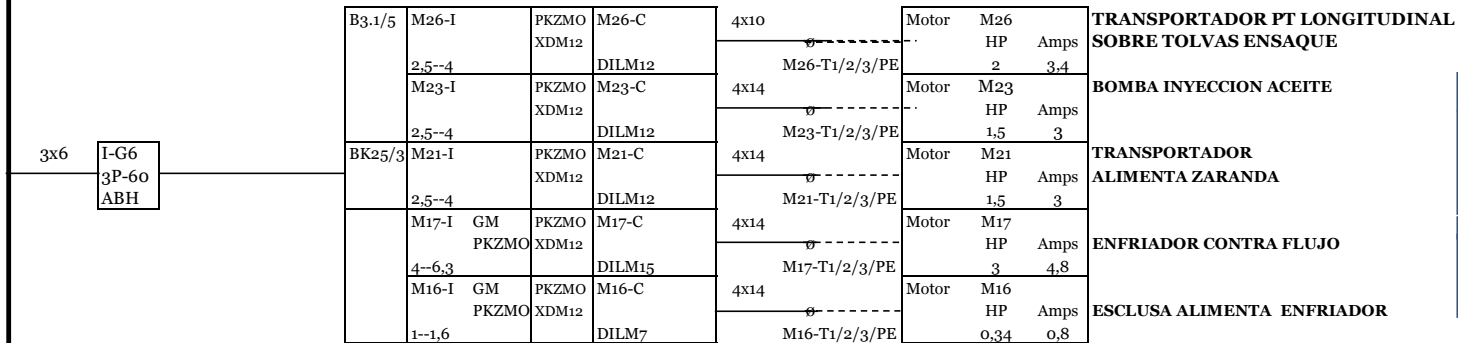

10--16	92,4	27,72	DILM15	68
20--25	92,4	27,72	DILM32	85
6,3--10	92,4	27,72	DILM17	85
	45	13,5		45

B3.1/5		BK2		
GM M16-I 1/1,6	GM M17 -I 4/6,3	GM 21-I PKZMO 2,5/4	GM M23 -I PKZMO 2,5/4	GM M26 -I PKZMO 2,5/4
XDM32	XDM3	XDM3	XDM1	
M16-C	M17-C	M21-C	M23-C	M27-C
DIL M7	DIL	DIL	DIL	DIL

UVW

UNIFILAR CCM-PELET 600 HP FINCA MOSQUERA

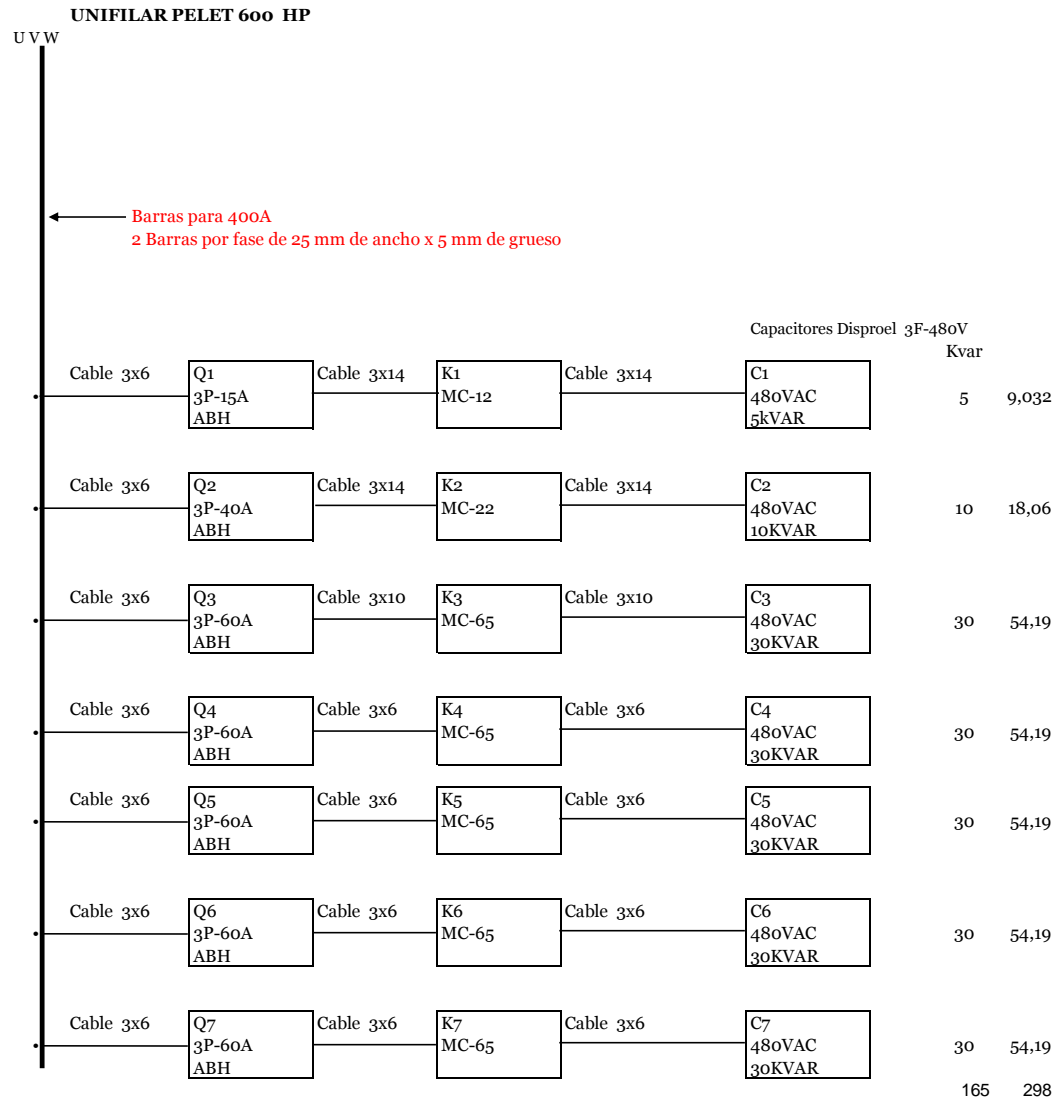

El Controlador de factor de potencia será DISPROEL FP-Rapidus de 6 pasos que es a la vez Analizador de redes
 Los condensadores serán marca Disproel 3 Fases 525 Vca- 60 Hz
 Las bobinas de los contactores serán para 120 Vca

DIAGRAMA DE FLUJO DE UNA PELETIZADORA CPM 600 HP

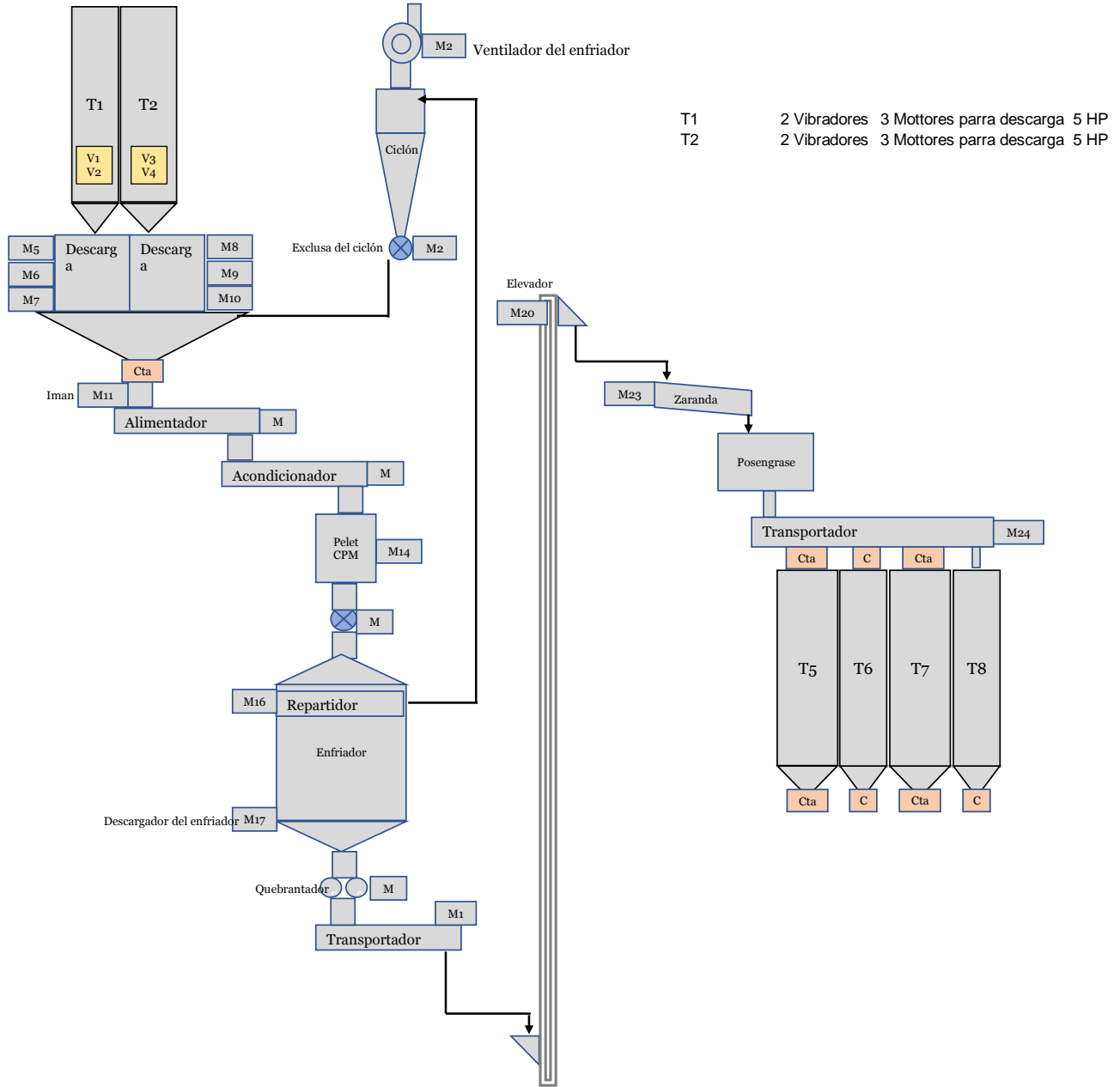

Vibradores (V1-V2-V3-V4)-(M16-M17-M18-M19)
● Sensores de Nivel

Notas:

- 1 Todos los sensores - Ctas serán manejados por el PLC
- 2 Los sensores de movimiento son los que confirman una adener de energización

CONTROL MOTORES PELETIZADORA 600 HP 3F-460V - 50 Ka

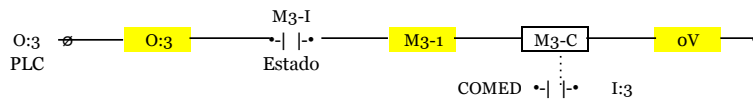
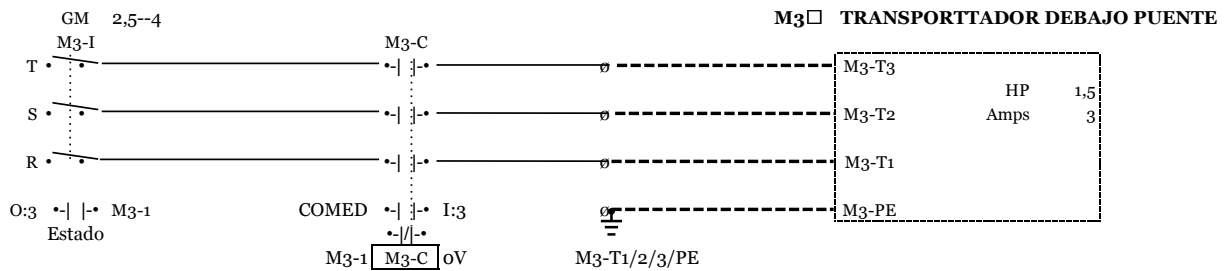
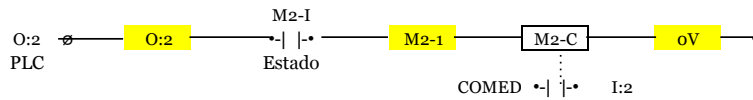
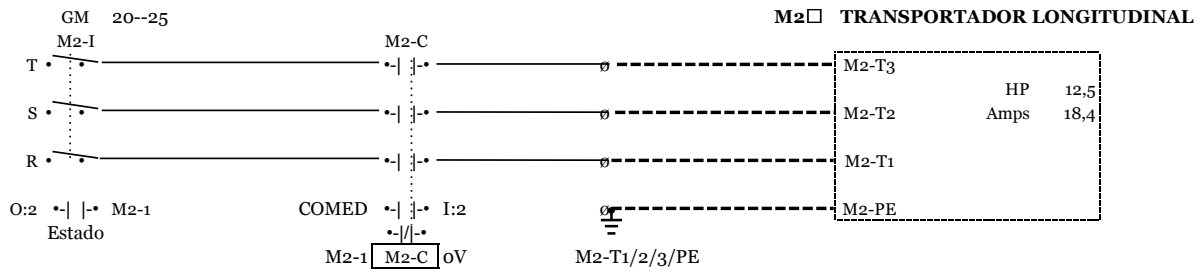
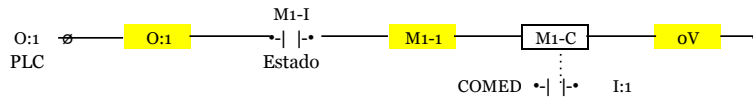
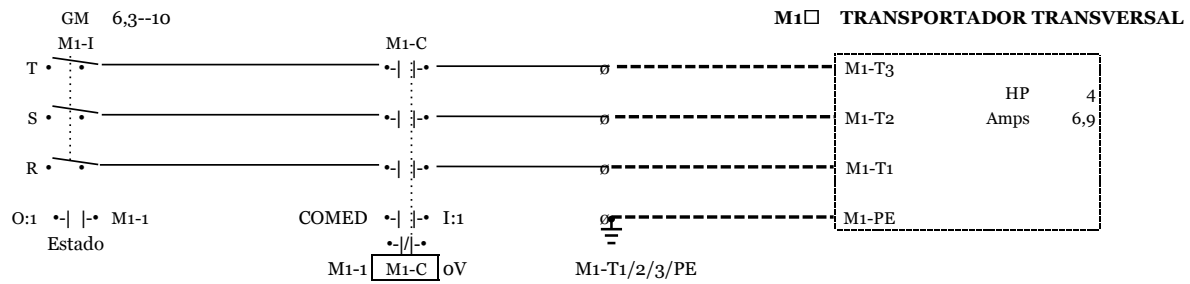

CONTROL MOTORES PELETIZADORA 600 HP FINCA MMOSQUERRA

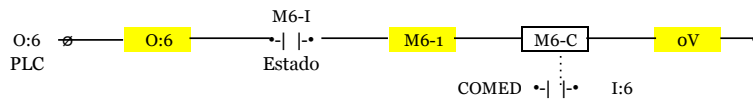
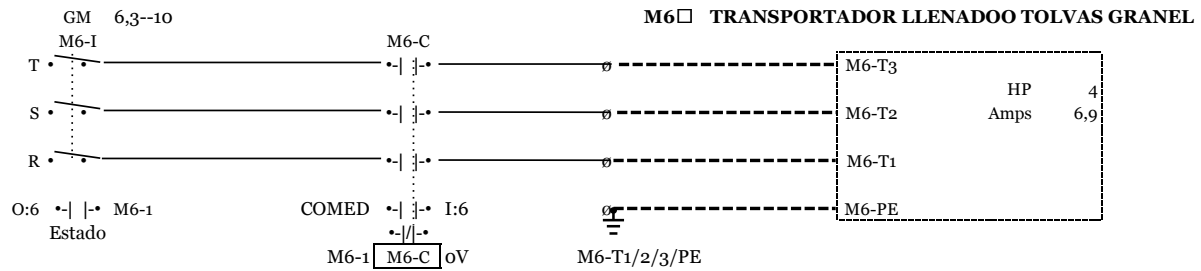
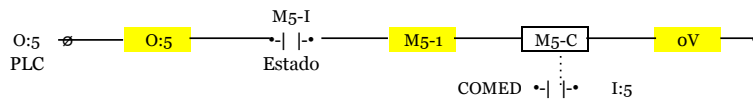
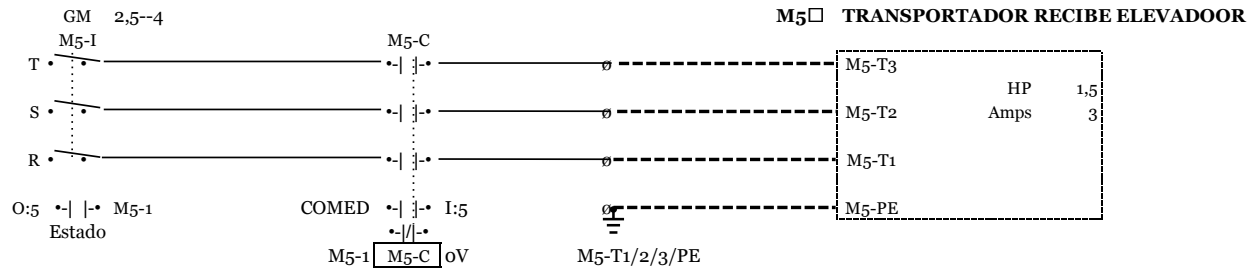
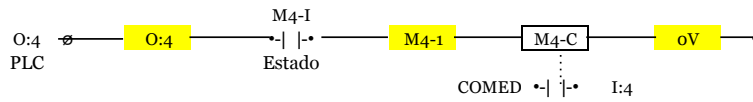
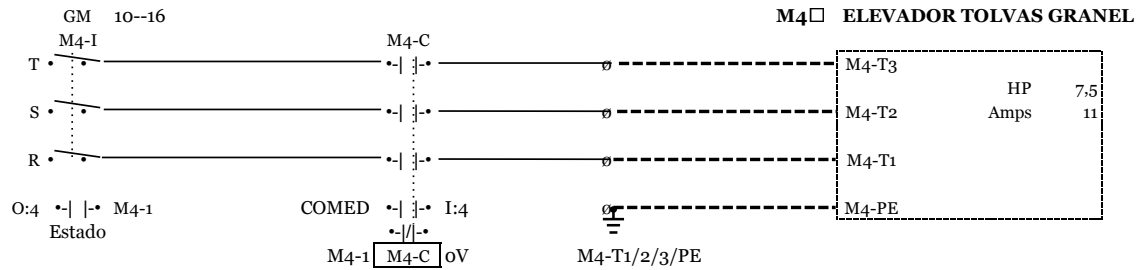

CONTROL MOTORES PELETIZADORA 600 HP FINCA MMOSQUERRA

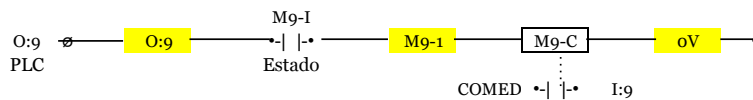
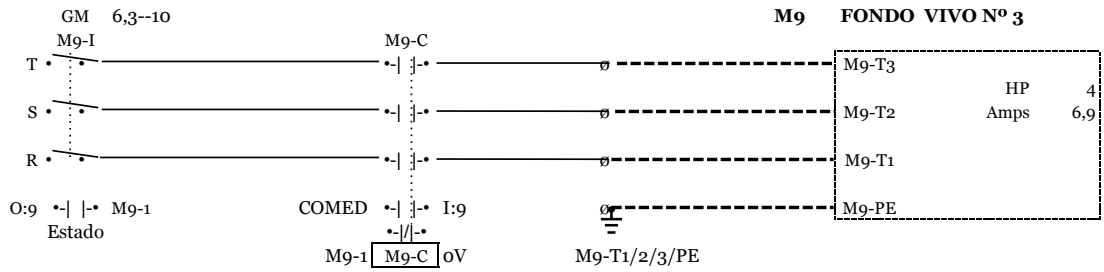
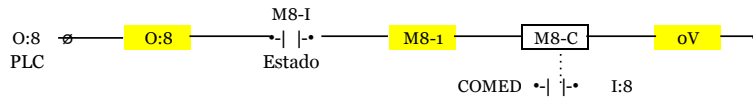
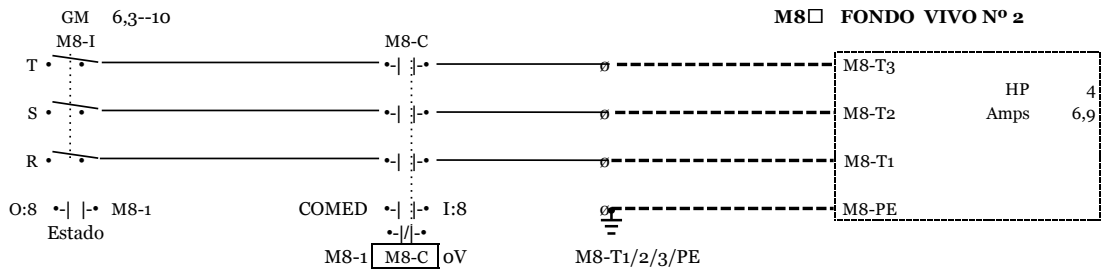
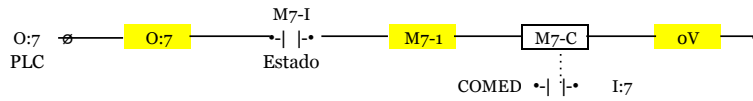
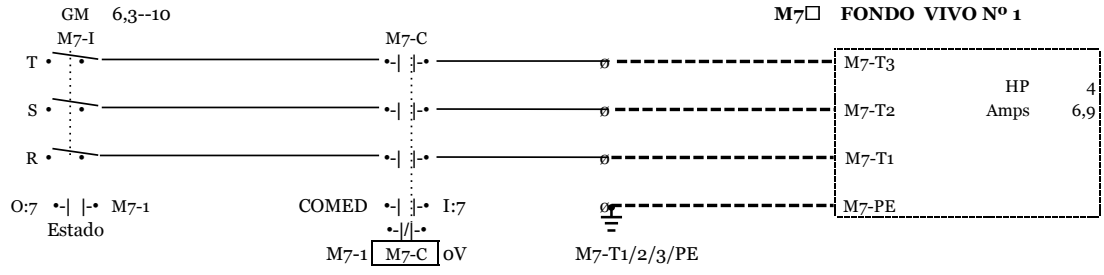

CONTROL MOTORES PELETIZADORA 600 HP FINCA MMOSQUERRA

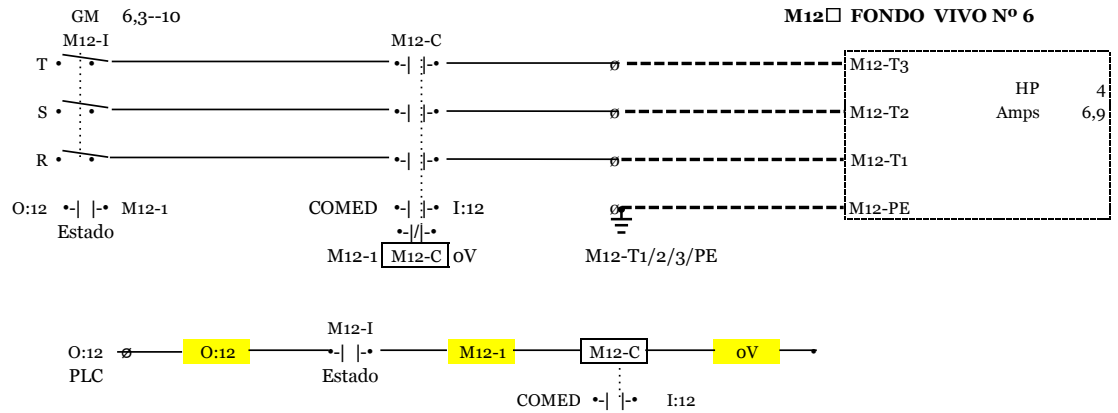
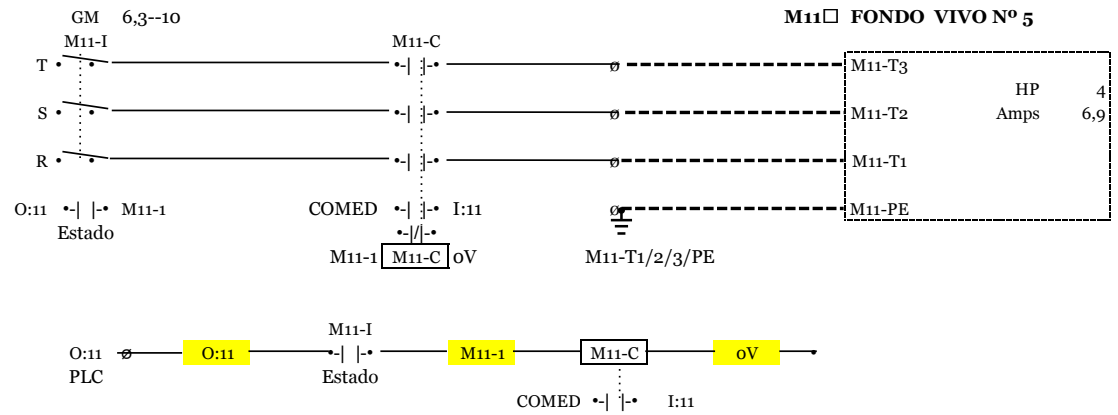
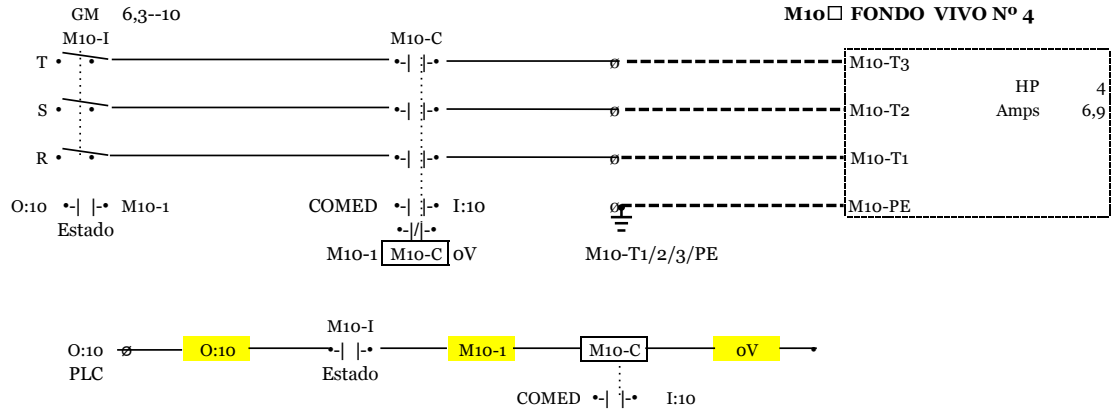

CONTROL MOTORES PELETIZADORA 600 HP FINCA MMOSQUERRA

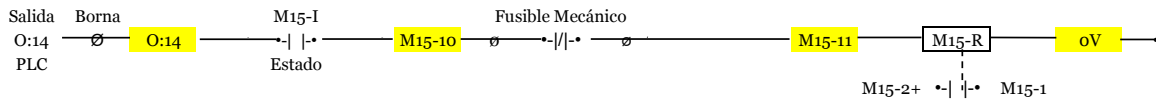
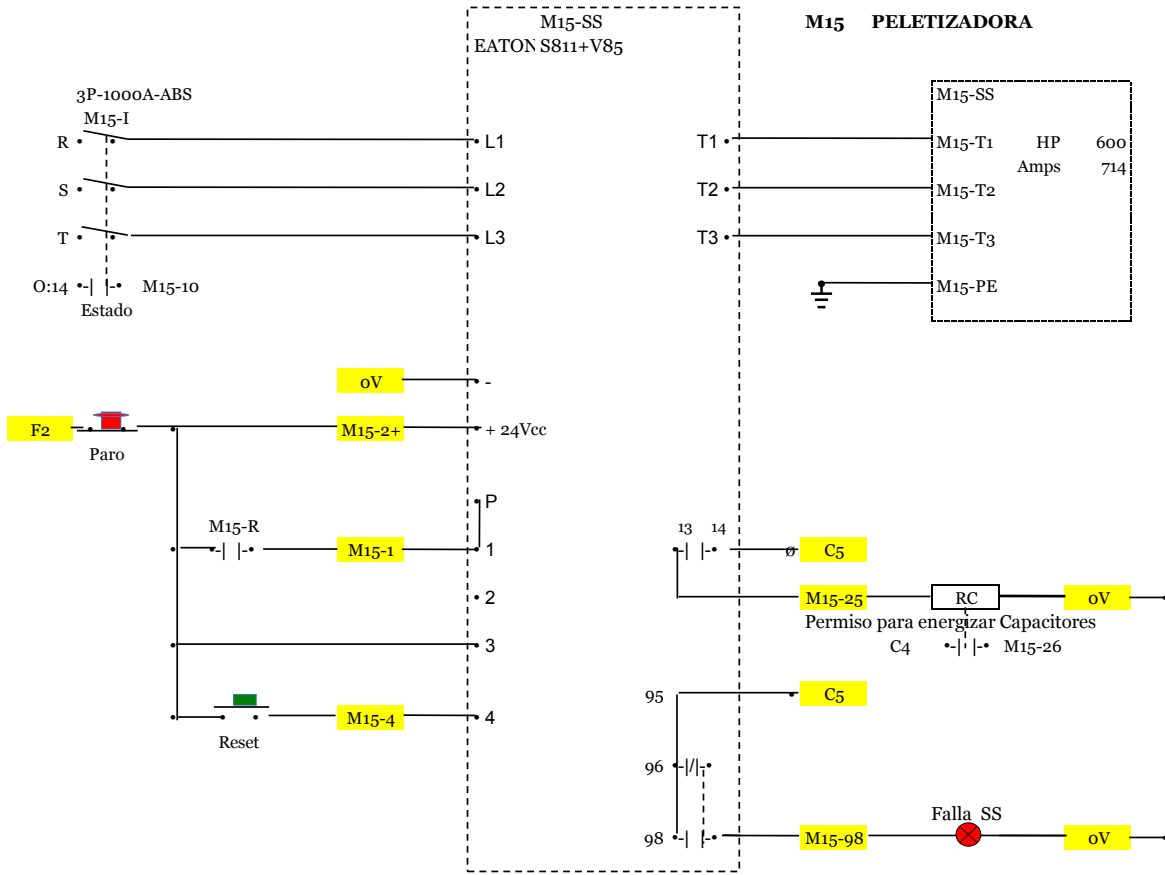

TEMPERATURA DEL MOTOR DE LA PELTZADORA

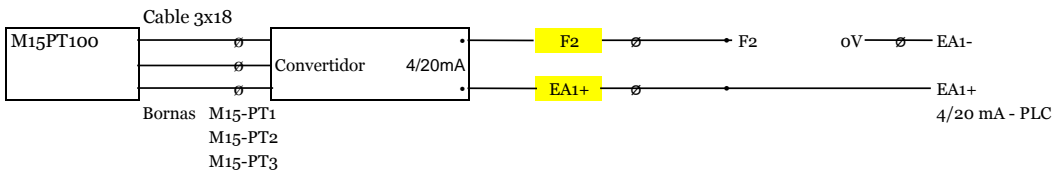

Suministrado por otros

CORRIENTE DEL MOTOR DE LA PELTZADORA

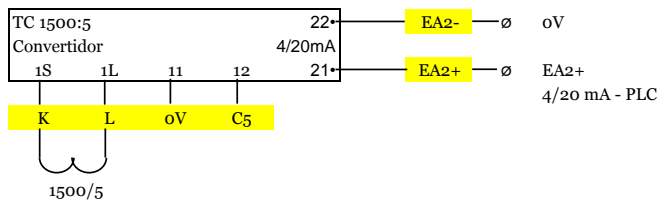

CONTROL MOTORES PELETIZADORA 600 HP FINCA MMOSQUERRA

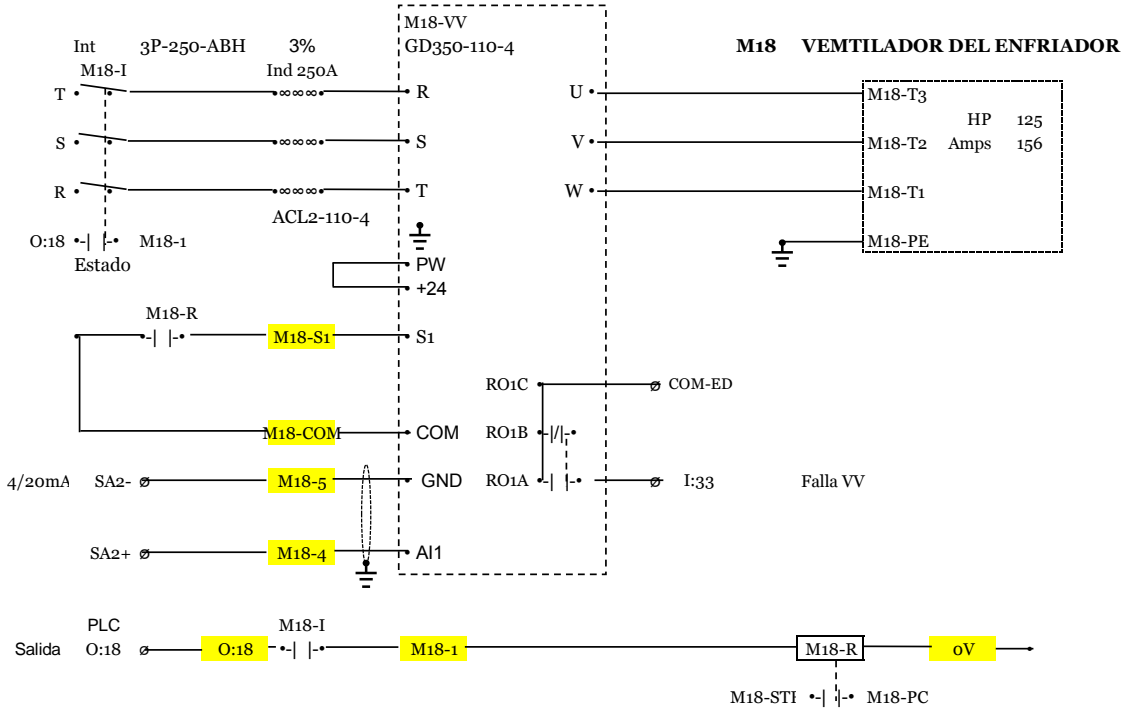
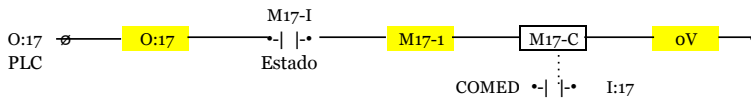
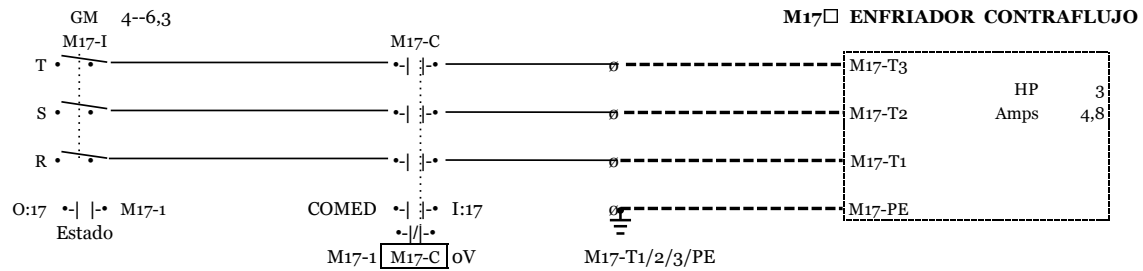
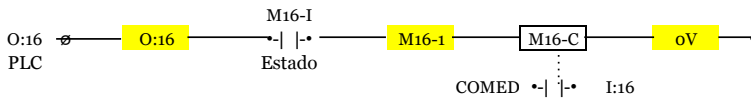
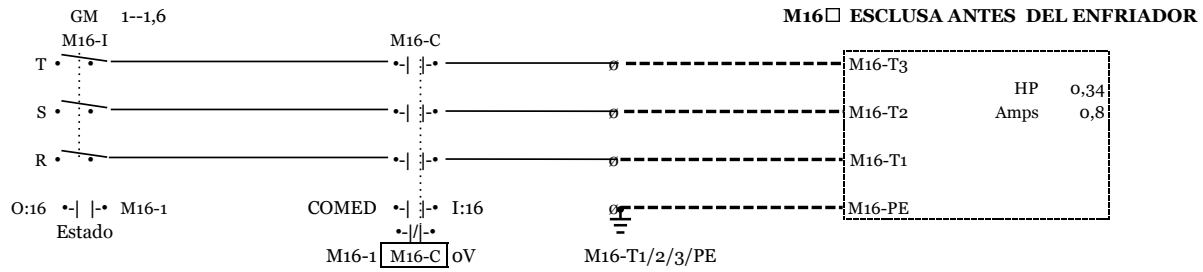

CONTROL MOTORES PELETIZADORA 600 HP FINCA MMOSQUERRA

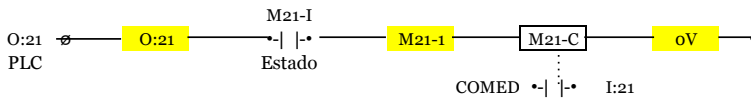
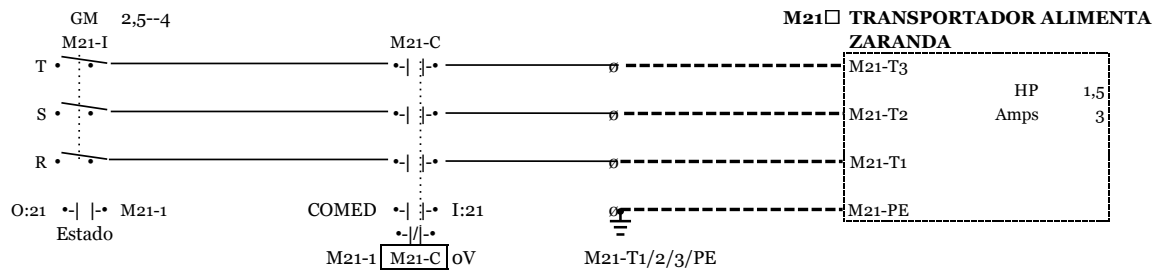
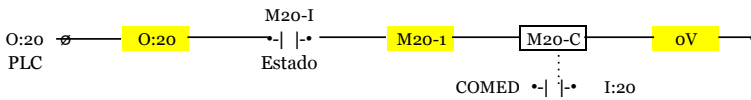
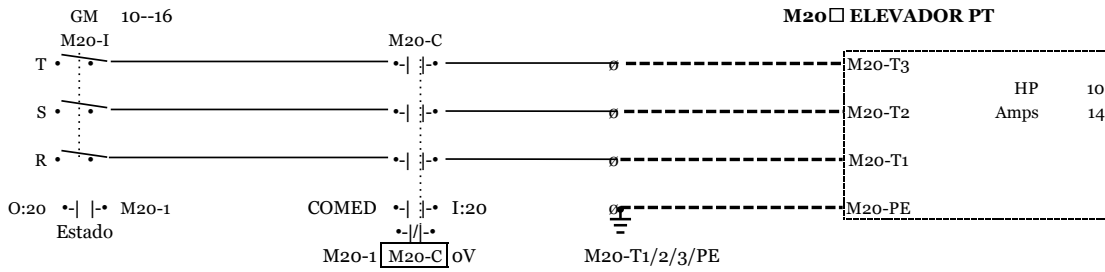
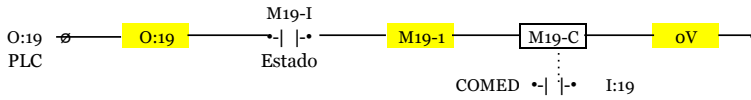
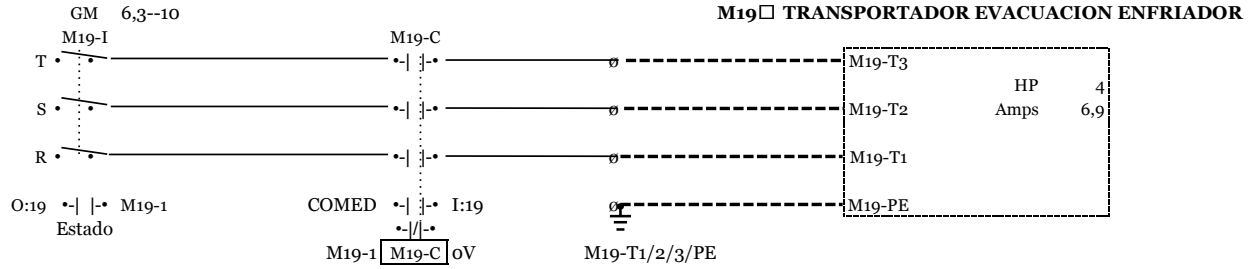

CONTROL MOTORES PELETIZADORA 600 HP FINCA MMOSQUERRA

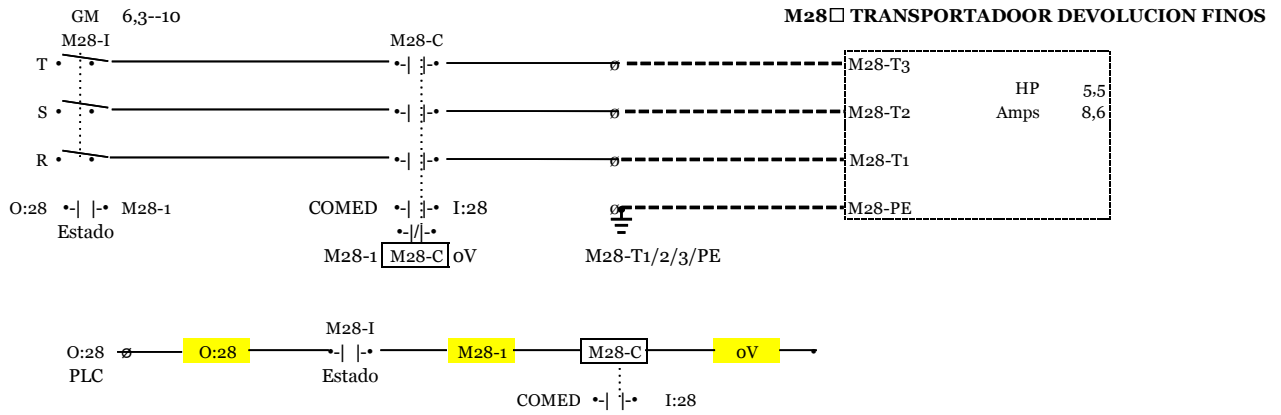

CONTROL MOTORES PELETIZADORA 600 HP FINCA MMOSQUERRA

		KW		HP					
M19		Transportador de cadena evacuacion Enfriador 6,2m	3	4,08	6,9	NA	6,3--10	DILM17	
M20		Elevador de Cangilones PT 23,4m	7,5	10,20	14	NA	10--16	DILM40	
		Equipos complementarios							
M21		Transportador Alimentador Zaranda 3,2m	1,1	1,50	3	NA	2,5--4	DILM12	
M22		Zaranda Rotex 205771E	7,5	10,20	14	NA	10--16	DILM40	
	22-250-3	Banda Pesadora Alimentadora Engrasador	0,75	1,02	2,1	NA	1,6--2,5	DILM12	
	22-250-3	Engrasador adicionador de Aceite	1,5	2,04	3,4	NA	2,5--4	DILM12	
	22-250-3	Homogenizador post engrase	3	4,08	6,9	NA	6,3--10	DILM17	
M23		Bomba Inyeccion Aceite Viking	1,1	1,50	3	NA	2,5--4	DILM12	
M24	22-250-4	Elevador Cangilones Post engrase 10,5m	4	5,44	8,6	NA	6,3--10	DILM17	
M25	22-250-5	Transportador PT Transversal Sobre Tolvas ensaque 13,5	4	5,44	8,6	NA	6,3--10	DILM17	
M26	22-250-6	Transportador PT Longitudinal Sobre Tolvas ensaque 4,5m	1,5	2,04	3,4	NA	2,5--4	DILM12	
M27		Esclusa Filtro Ciclon Metalteco	0,75	1,02	2,1	NA	1,6--2,5	DILM12	
M28		Transportador sinfin de Devolucion Finos 9,8m	4	5,44	8,6	NA	6,3--10	DILM17	

TABLEROS - CCM- P5 600 HP

3F-460V 50 Ka a 460V

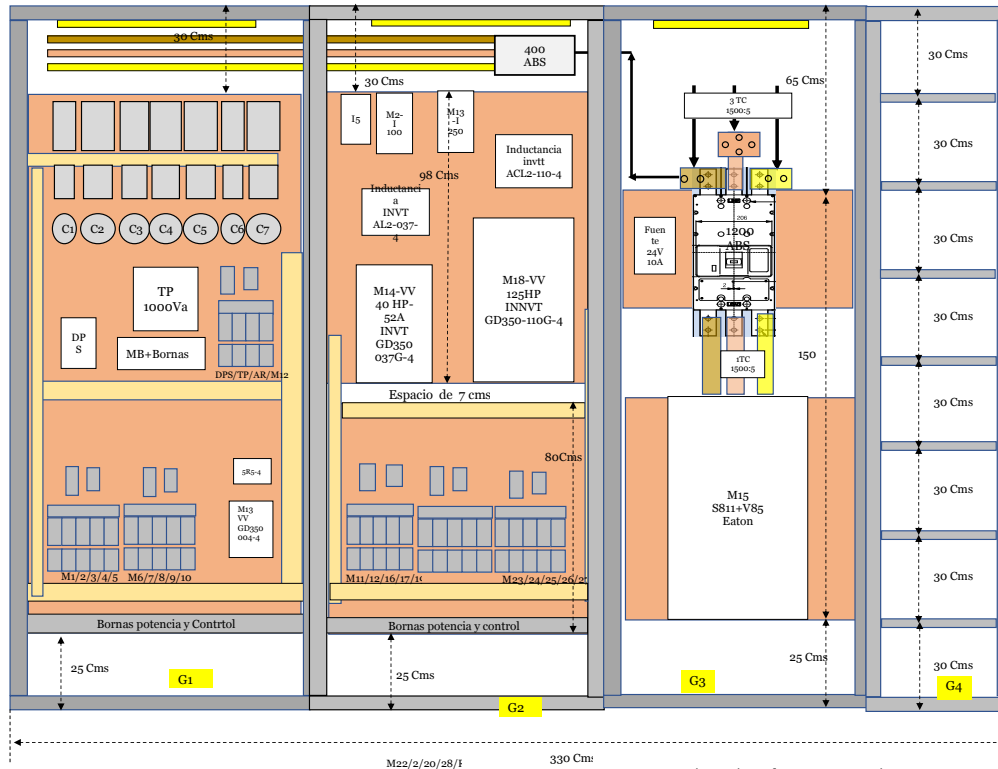

Dimensiones en metros

	G1	G2	G3	G4	Total	m2	Kilos
Altura	2,4	2,4	2,4	2,4	2,4	39,8	608,9
Ancho	1	1	0,9	0,4	3,3		
Prof.	0,6	0,6	0,6	0,6	0,6		
Lámina	14						
Color	Ral 7032						
IP	60						
m2	10,164	10,164	6,93	3,96			
Kg	155,5092						

Dimensiones de SS

	Eaton	Siemes	ABB	Amps
Altura	421	764	493	850
Ancho	281	478	435	
Prof	188	241	369	

Las barras que alimentan los Int de 500A-ABN803c serrán de 20x5mm
 Las barras que alimentan los S811+U42 de 500A-ABN803c serrán de 20x5mm

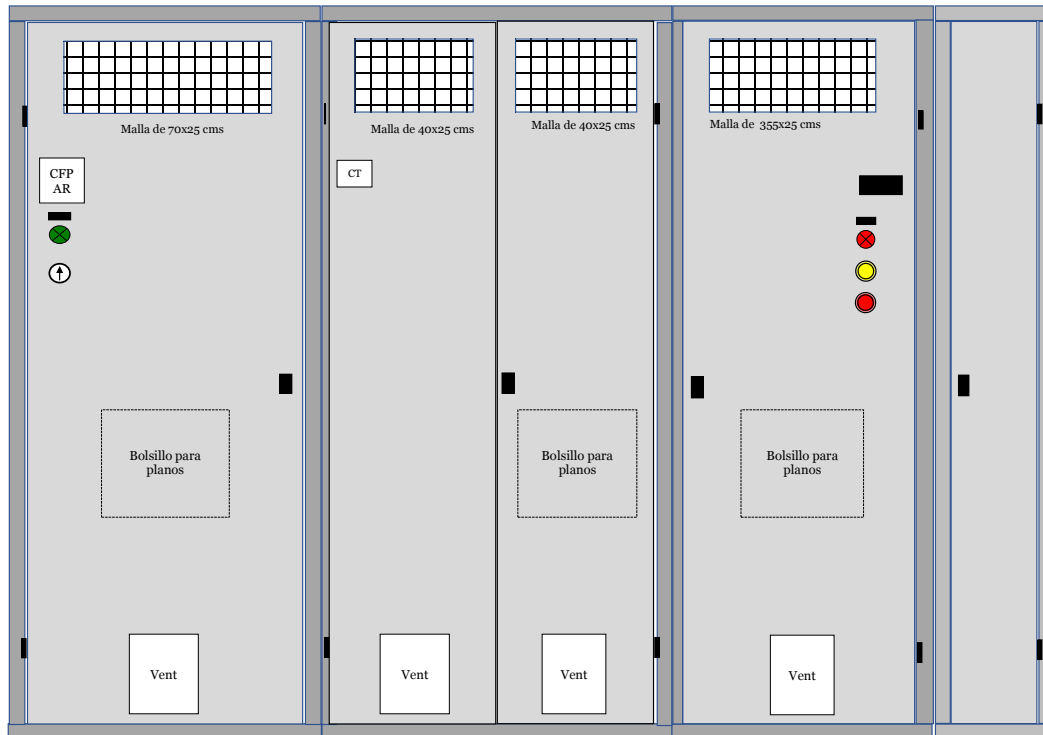



ASI SE DEBEN ARMAR LAS ESTRUCTURAS

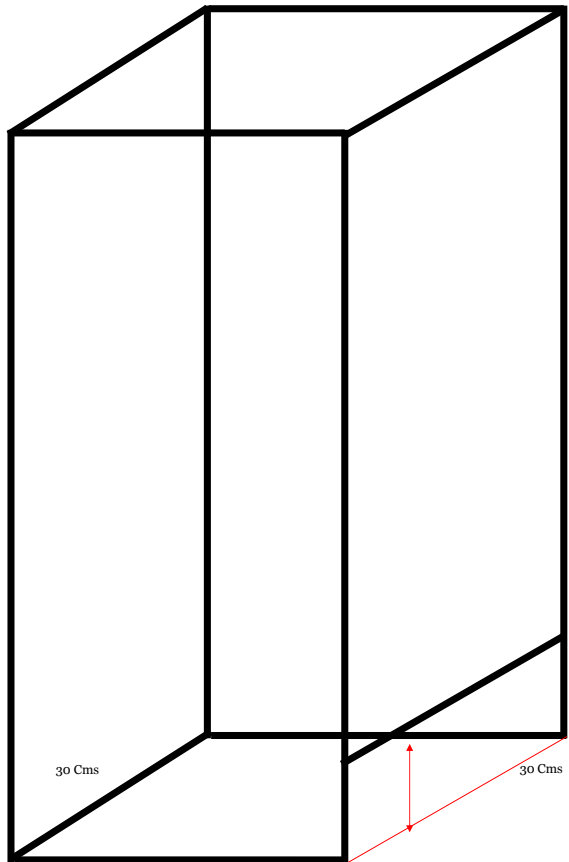

Puerta al frete
Tapa atras
Sin tapas laterales
Tapa en la parte superior
Sin tapa en la parte inferior

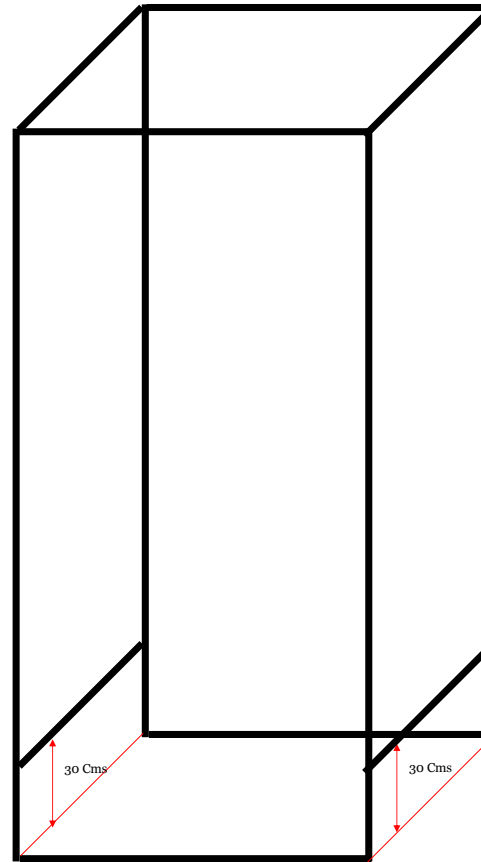

Puerta al frete
Tapa atras
Sin tapas laterales
Tapa en la parte superior
Sin tapa en la parte inferior

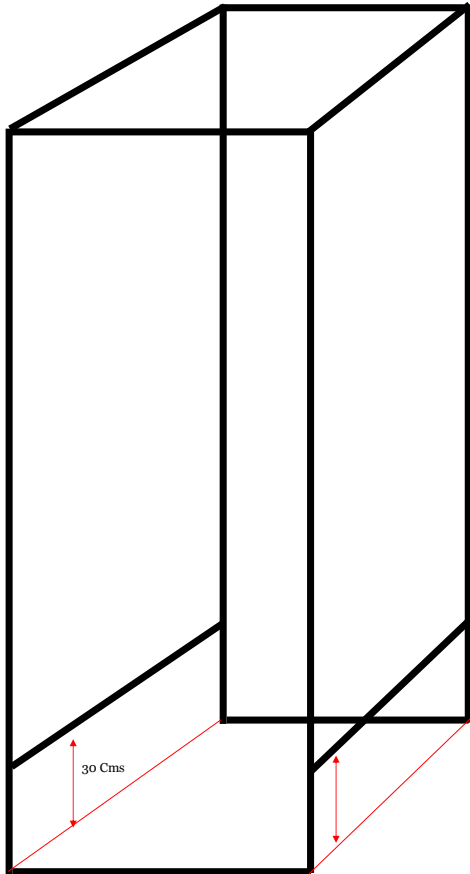

- Puerta al frente lámina 16 2,5
- Tapa atras 2,5
- Sin tapa al lado derecho 0
- Tapa al lado Izquierdo 1,5
- Tapa en la parte superior 0,6
- Sin tapa en la parte inferior 0
- 7,1

	Metros	m2	Kg
Longitud perfiles calibre 1.	16,4	1,968	28,06368
Meros cuadrados tapas			86,691
			120,492414

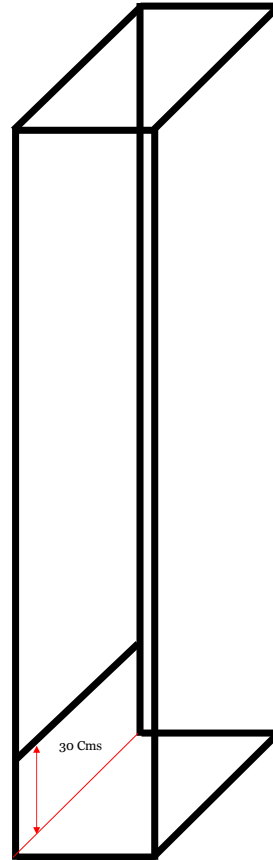

- Puerta al frente
- Tapa atras
- Tapa al lado derecho
- Tapa de - 30 cms de altura
- Sin tapa en la parte superior
- Sin tapa en la parte inferior

CCM-P4- 600 HP FINCA MOSQUERA

DIMENSIONES LÁMINA

Calibre	Ancho m	Largo m	Peso/m2	Peso lámina
16	1,22	2,44	12,21	36,3
14	1,22	2,44	14,26	42,4
12	1,22	2,44	21,36	63,6

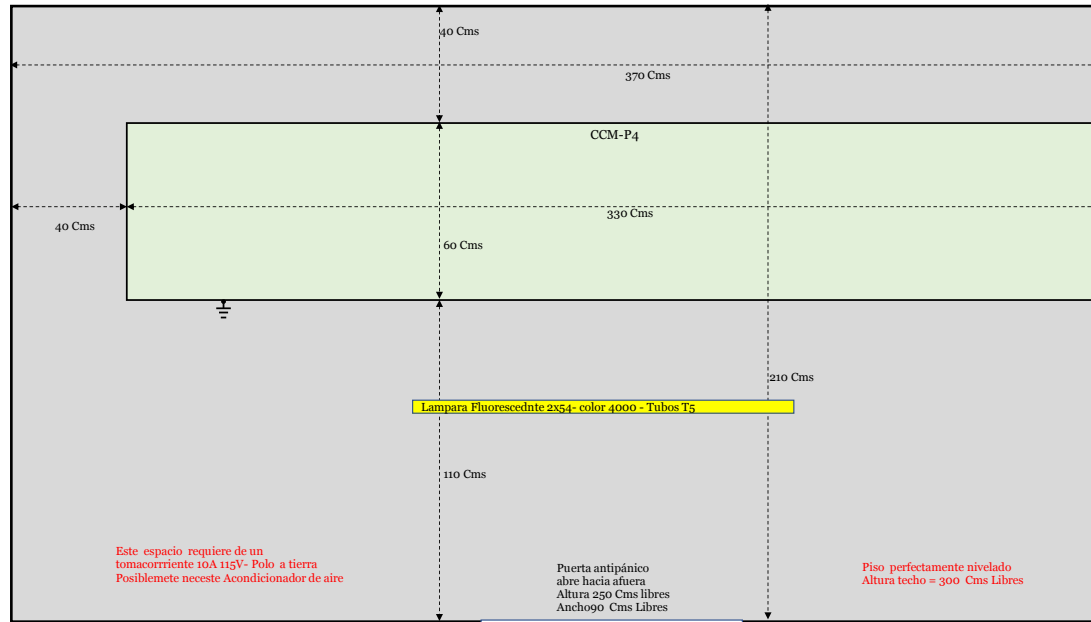

BORNAS PELETIZADIRA 600 HP FINCA MOSQUERA

BORNAS - POTENCIA

M1-T1
M1-T2
M1-T3
M1-PE
Separador
M2-T1
M2-T2
M2-T3
M2-PE
Separador
M3-T1
M3-T2
M3-T3
M3-PE
Separador
M4-T1
M4-T2
M4-T3
M4-PE
Separador
M5-T1
M5-T2
M5-T3
M5-PE
Separador
M6-T1
M6-T2
M6-T3
M6-PE
Separador
M7-T1
M7-T2
M7-T3
M7-PE
Separador
M8-T1
M8-T2
M8-T3
M8-PE
Separador
M9-T1
M9-T2
M9-T3
M9-PE
Separador
M10-T1
M10-T2
M10-T3
M10-PE
Separador
M11-T1
M11-T2
M11-T3
M11-PE
Separador
M12-T1
M12-T2
M12-T3
M12-PE
Separador
M13-T1
M13-T2
M13-T3
M13-PE
Separador
M16-T1
M16-T2
M16-T3
M16-PE
Separador
M17-T1
M17-T2
M17-T3
M17-PE
Separador
M19-T1
M19-T2
M19-T3
M19-PE
Separador
M20-T1
M20-T2
M20-T3
M20-PE
Separador
M21-T1
M21-T2
M21-T3
M21-PE
Separador
M22-T1
M22-T2
M22-T3
M22-PE
Separador
M23-T1
M23-T2
M23-T3
M23-PE
Separador
M24-T1
M24-T2
M24-T3
M24-PE
Separador
M25-T1
M25-T2
M25-T3
M25-PE
Separador
M26-T1
M26-T2
M26-T3
M26-PE
Separador
M27-T1
M27-T2
M27-T3
M27-PE
Separador
M28-T1
M28-T2
M28-T3
M28-PE
Separador

BORNAS CONTROL

COM-ED
I:1
I:2
I:3
I:4
I:5
I:6
I:7
I:8
Separador
COM-ED
I:9
I:10
I:11
I:12
I:13
I:14
I:15
I:16
Separador
COM-ED
I:17
I:18
I:19
I:20
I:21
I:22
I:23
I:24
Separador
COM-ED
I:25
I:26
Separador
O:1
O:2
O:3
O:4
O:5
O:6
O:7
O:8
Separador
O:9
O:10
O:11
O:12
O:13
O:14
O:15
O:16
Separador
O:17
O:18
O:19
O:20
O:21
O:22
O:23
O:24
Separador
O:25
O:26
Separador
M12-R
M13-R
M14-R
Separador
1P-4
1P-6
1P-3
Separador
1P-10
1P-2

DC

GM
1--1,6
GM
1,6-4
Separador
1P-10
1P-4
1P-6
1P-6
Separador
2
2
2
Separador
oV
oV
oV
oV
oV
oV
Separador
M14PT1
M14PT2
M14PT3
F2
M14EA1-
M14EA1+
Separador
F2
M14EA2-
M14EA2+
Separador
M21SA-
M21SA+