

CCM-BS

3F-208V-60Hz-10 Ka

DIAGRAMA DE POTENCIA

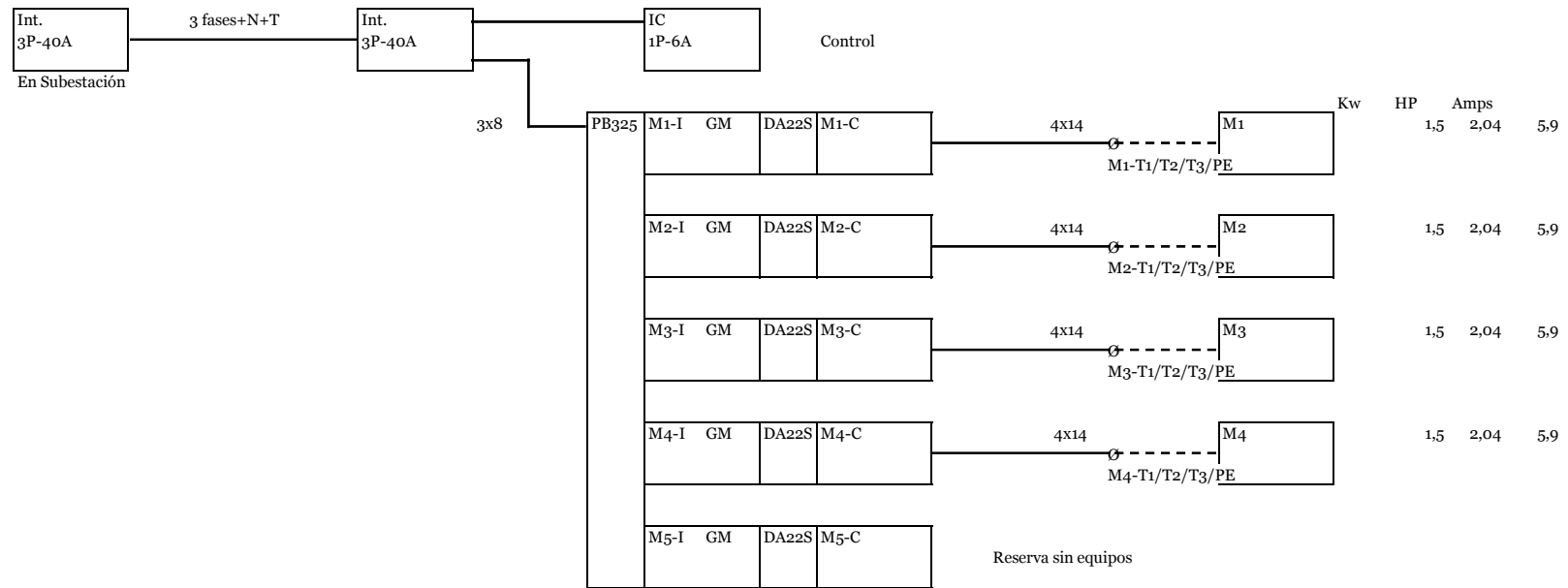

Todos los guardamotores tendrán un contacto auxiliar NO (Estado)- FRONTAL

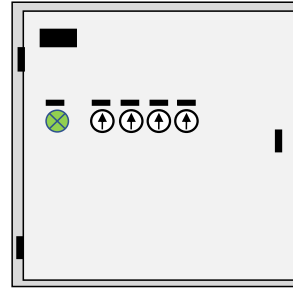
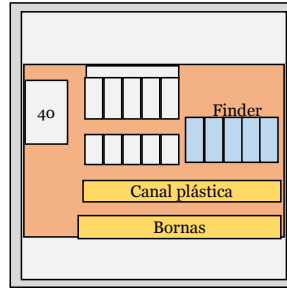

Dimensiones en metros
 Altura 0,75 m2 Kg
 Ancho 0,75 2,846 42,69
 Prof 0,3
 Lámina 14
 Color RAL 7032
 IP 60

BORNNAS POTENCIA

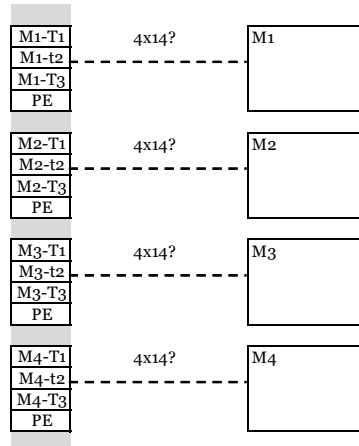

BORNNAS CONTYROL

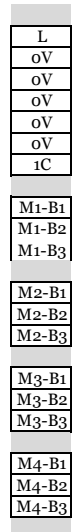

RELES Y SENSORES DE NIVEL

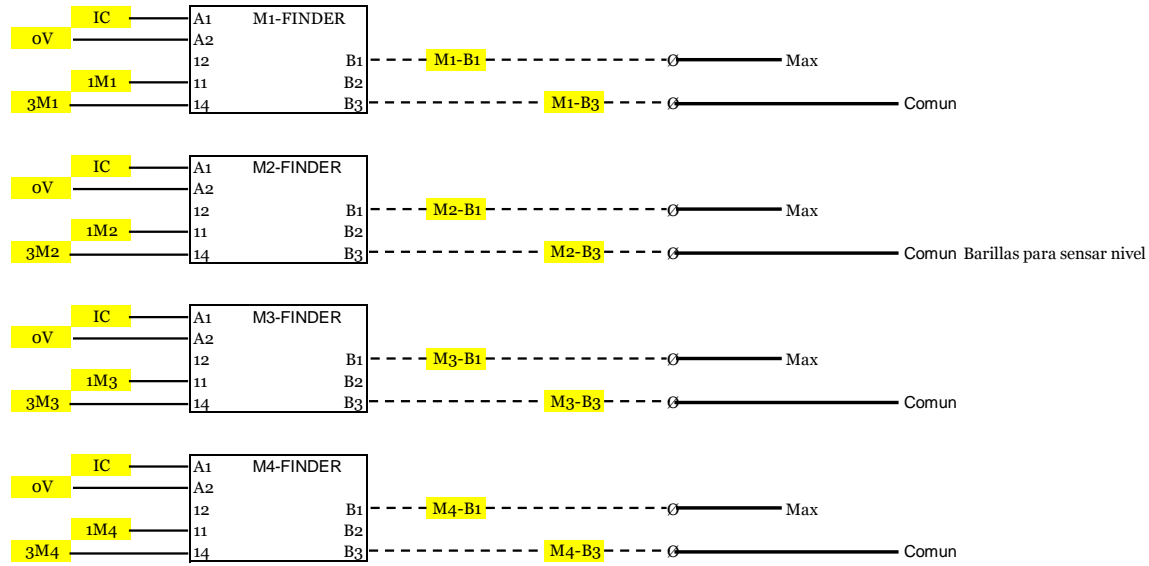

CCM-BS
3F-208V- 60 Hz- 10 Ka

Placa de 5 x10 Cms

BOMBA N° 1
1,5 Kw - 3F-208V

CONTROL
115v

BOMBA N° 2
1,5 Kw - 3F-208V

SELECTOR-B1
MAN-O-AUT

BOMBA N° 3
1,5 Kw - 3F-208V

SELECTOR-B2
MAN-O-AUT

BOMBA N° 4
1,5 Kw - 3F-208V

SELECTOR-B3
MAN-O-AUT

SELECTOR-B4
MAN-O-AUT