

FINCA - BUGA

3 Fases - 460Vca - 36 Ka a 460Vca

CCM-Recibo materia prima

Nº Motor	Código	Nombre	HP	Amps	Arranc.	GM	Ref SS	Contactor	Cable
M 1	ASPO01	Filtro recibo 1	25	34	SS	MMS-32S, 28-40 A	RVS-DX58		
M 2	ASPO02	Filtro recibo 2	25	34	SS	MMS-32S, 28-40 A	RVS-DX58		
M 3	PLAO01	Plataforma volcadora 001	50	65	SS	ABN-103d, 75 A	RVS-DX72		
M 4	TRAO01	Transportador tolva recibo	10	14	D	MMS-32S, 14-22 A		MC-22b	
M 5	ELEO01	Elevador tolva recibo	100	124	SS	ABN-203c, 150 -A	RVS-DX130		
M 6	TRAO02	Transportador cargue 4 silos	30	40	SS	MMS-63S, 34-50 A	RVS-DX72		
M 7	TRAO03	Transportador cargue silo 1 y 2	15	21	D	MMS-32S, 18-26 A		MC-32a	
M 8	TRAO04	Transportador cargue silo 3 y 4	15	21	D	MMS-32S, 18-26 A		MC-32a	
M 9	TSMO01	Sinfin 1 descarga silo 1	10	14	D	MMS-32S, 14-22 A		MC-22b	
M 10	TSMO02	Sinfin 2 descarga silo 1	10	14	D	MMS-32S, 14-22 A		MC-22b	
M 11	TSMO03	Sinfin 1 descarga silo 2	10	14	D	MMS-32S, 14-22 A		MC-22b	
M 12	TSMO04	Sinfin 2 descarga silo 2	10	14	D	MMS-32S, 14-22 A		MC-22b	
M 13	TSMO05	Sinfin 1 descarga silo 3	10	14	D	MMS-32S, 14-22 A		MC-22b	
M 14	TSMO06	Sinfin 2 descarga silo 3	10	14	D	MMS-32S, 14-22 A		MC-22b	
M 15	TSMO07	Sinfin 1 descarga silo 4	10	14	D	MMS-32S, 14-22 A		MC-22b	
M 16	TSMO08	Sinfin 2 descarga silo 4	10	14	D	MMS-32S, 14-22 A		MC-22b	
M 17	TRAO50	Transportador inclinado descarga silos	15	21	D	MMS-32S, 18-26 A		MC-32a	
M 18	ELEO02	Elevador carga bascula de paso	15	21	D	MMS-32S, 18-26 A		MC-32a	
M 19	TRAO04	Transportador trasiego 1	10	14	D	MMS-32S, 14-22 A		MC-22b	
M 20	TRAO05	Transportador trasiego 2	10	14	D	MMS-32S, 14-22 A		MC-22b	
M 21	TRAO06	Transportador trasiego 3	5	7,6	D	MMS-32S, 6-10 A		MC-12b	
M 22	SECO01	Secador	4	7,6	D	MMS-32S, 6-10 A		MC-12b	
M 23		Reserva no equipada	15	21	D				
M 24		Reserva no equipada	10	14	D				
M 25		Reserva no equipada	10	14	D				
M 26		Reserva no equipada	5	7,6	D				
M 27		Reserva no equipada	5	7,6	D				

454,0 614,4

Gabinete adicional lado derecho

M 28	VENO01	Ventilador Silo 1	5	7,6	D	MMS-32S, 6-10 A		MC-12b	
M 29	VENO02	Ventilador Silo 1	5	7,6	D	MMS-32S, 6-10 A		MC-12b	
M 30	VENO03	Ventilador Silo 2	5	7,6	D	MMS-32S, 6-10 A		MC-12b	
M 31	VENO04	Ventilador Silo 2	5	7,6	D	MMS-32S, 6-10 A		MC-12b	
M 32	VENO05	Ventilador Silo 3	5	7,6	D	MMS-32S, 6-10 A		MC-12b	
M 33	VENO06	Ventilador Silo 3	5	7,6	D	MMS-32S, 6-10 A		MC-12b	
M 34	VENO07	Ventilador Silo 4	5	7,6	D	MMS-32S, 6-10 A		MC-12b	
M 35	VENO08	Ventilador Silo 4	5	7,6	D	MMS-32S, 6-10 A		MC-12b	
M 36	ROSO01	Rosca barredora Silo 1	7,5	10	D	MMS-32S, 9-13 A		MC-12b	
M 37	ROSO02	Rosca barredora Silo 2	7,5	10	D	MMS-32S, 9-13 A		MC-12b	
M 38	ROSO03	Rosca barredora Silo 3	7,5	10	D	MMS-32S, 9-13 A		MC-12b	
M 39	ROSO04	Rosca barredora Silo 4	7,5	10	D	MMS-32S, 9-13 A		MC-12b	

524,0 715,2

Total amperios al mismo tiempo 357,6
 Total Kva al mismo tiempo 284,6
 Total amperios con el 50% adicional 536,4

Notas

El voltaje de control de los contactores es a 110V
 Totalizador de 500 Amperios -

TRANSFORMADOR PARA CONTROL

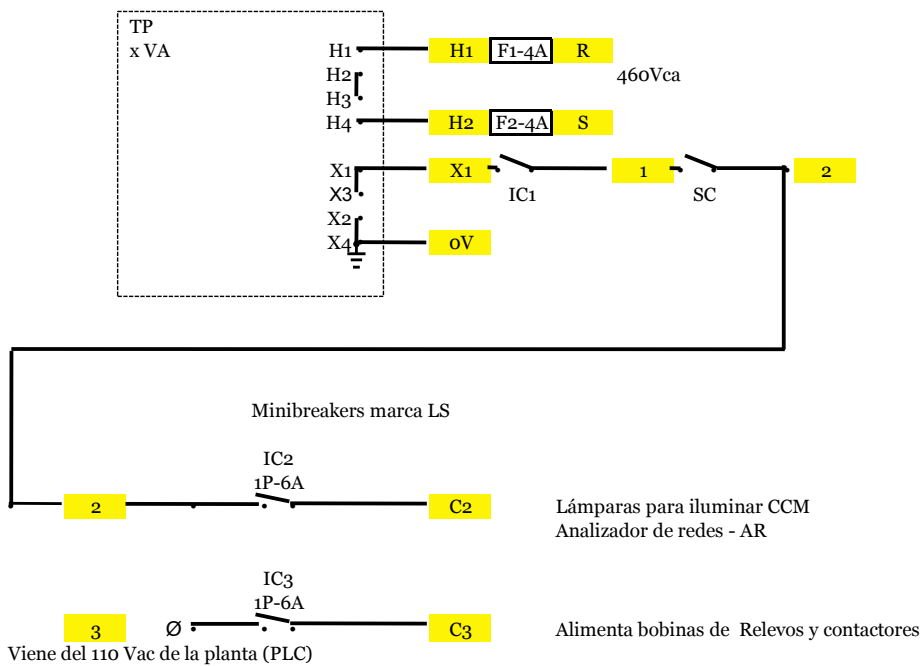
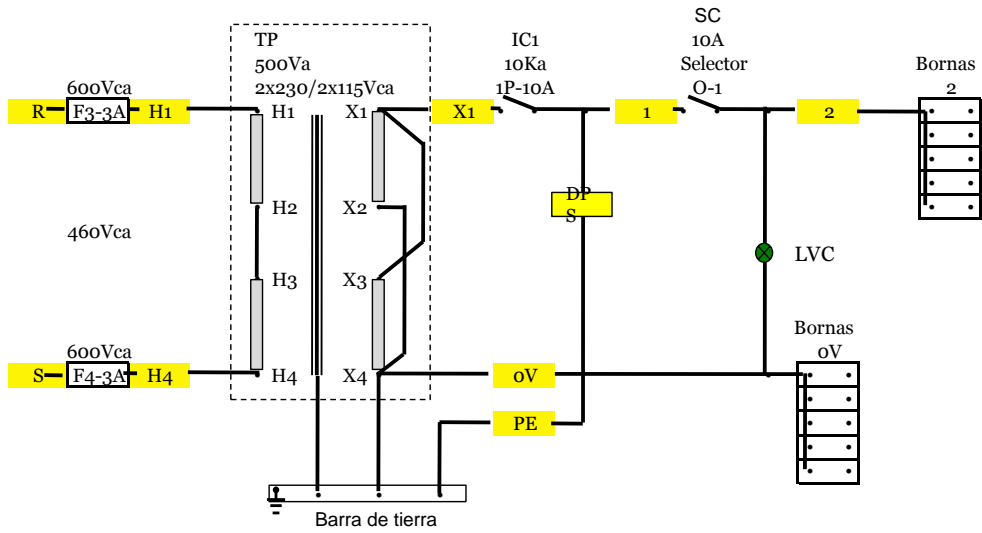

- TP Transformador para control 500 Va - Voltaje primario (2 devanados cada uno para 230 Vca)
Voltaje secundario (2 devanados cada uno para 115 Vca)-
Debe llevar pantalla electrostática para conectar a tierra
- Move DPS- LEVINTON 5280-W o Prosurge
- LVC Luz verde - Indica que hay voltaje para control
- O-1 Selector 10A , instalado en la puerta del CCM - Habilita el control.

ILUMINACION DE GABINETES

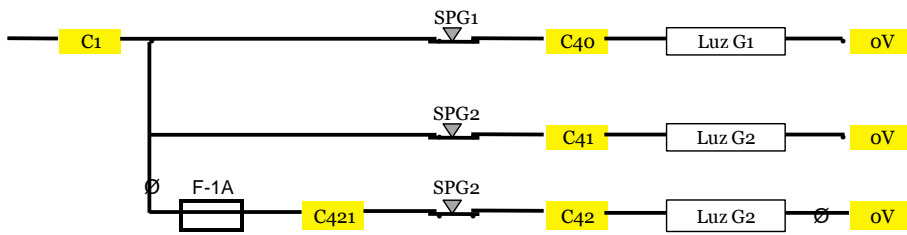

- SPG1 Suiches de puerta G1
- LUZ G1 Luz fluorescente de 30 Cms.
- SPG2 Suiches de puerta G2
- LUZ G2 Luz fluorescente de 30 Cms.
- SPG3 Suiches de puerta G3
- LUZ G3 Luz fluorescente de 30 Cms.

Por cada gabinete se instala una luz fluorescente para iluminar el gabinete, la luz se energiza por medio de un suiche instalado de tal manera que al abrir la puerta la luz se encienda y al cerrar la puerta la lámpara se desenergice.

DIAGRAMA PARA CONECTAR EL ANALIZAR DE REDES

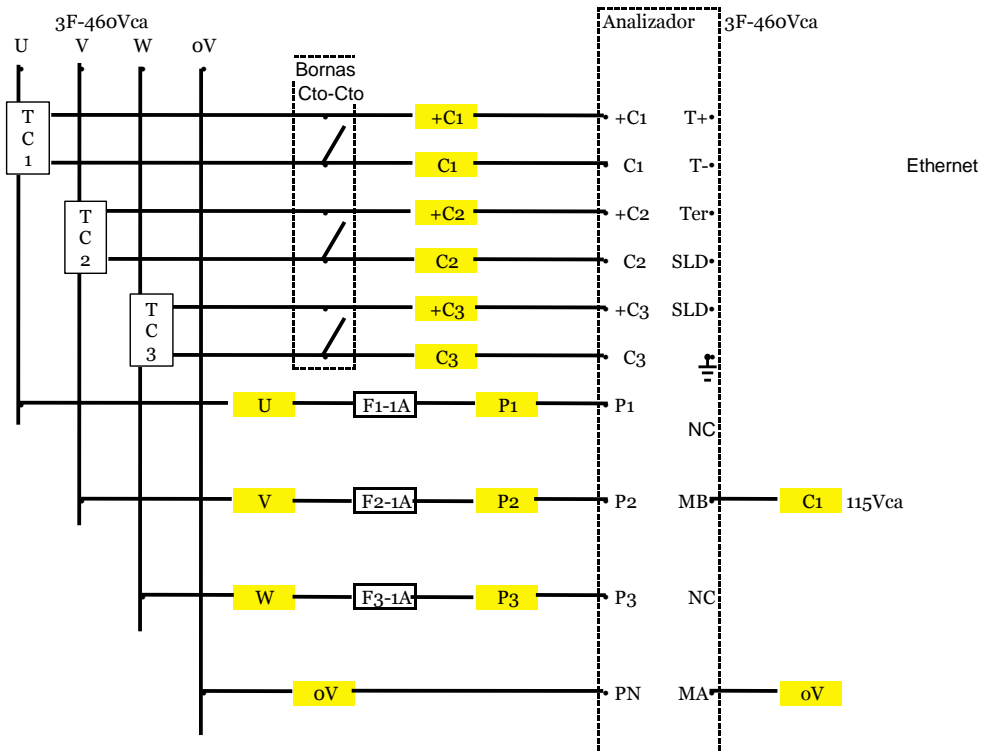

Notas

- 1 Los tres TC con Relación 500/5 .
- 2 Para los tres TC se deben colar bornas para cortocircuito

DIAGRAMA DE POTENCIA

3 Fases - 460 Vca - 36 Ka

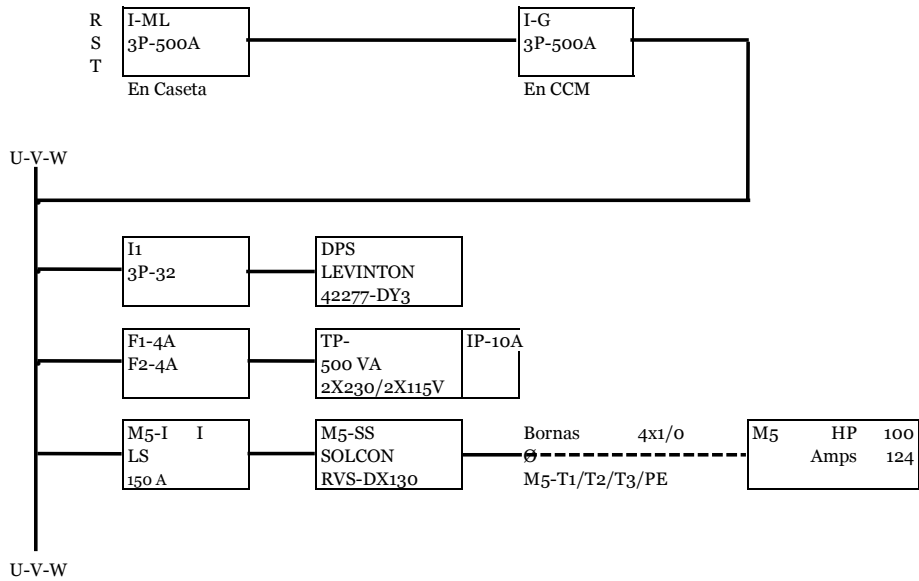

U-V-W

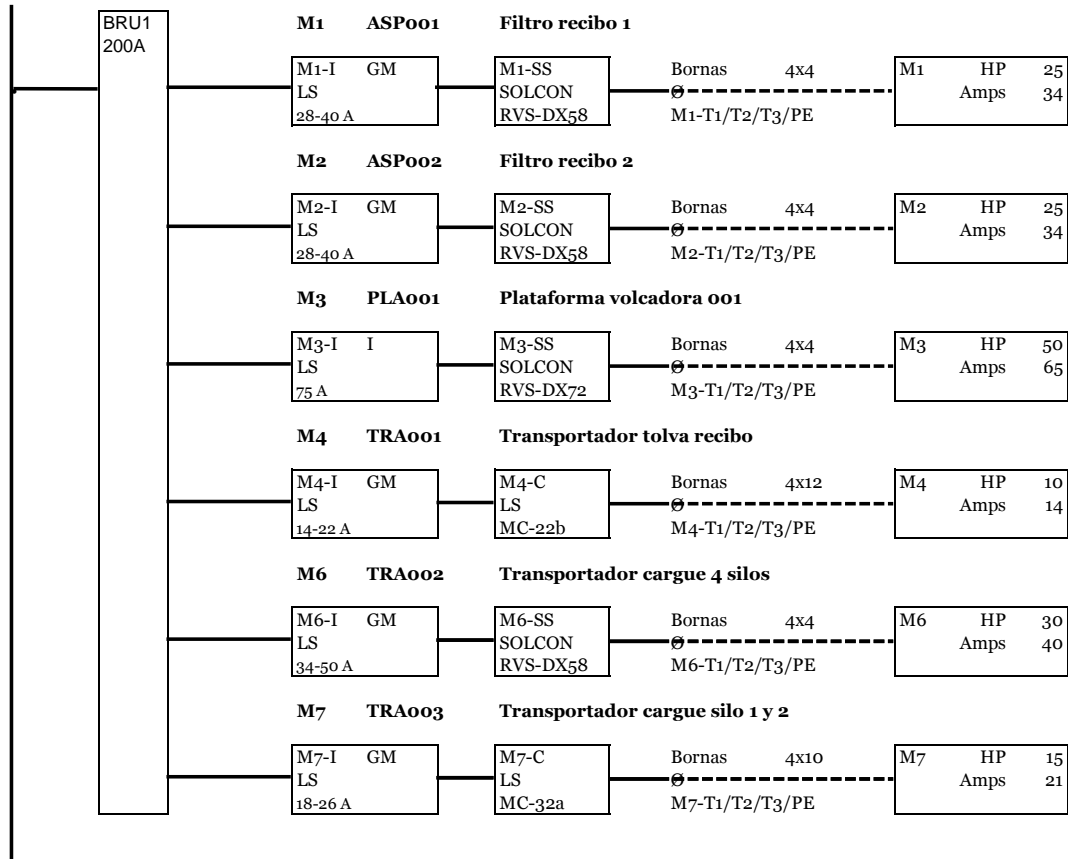

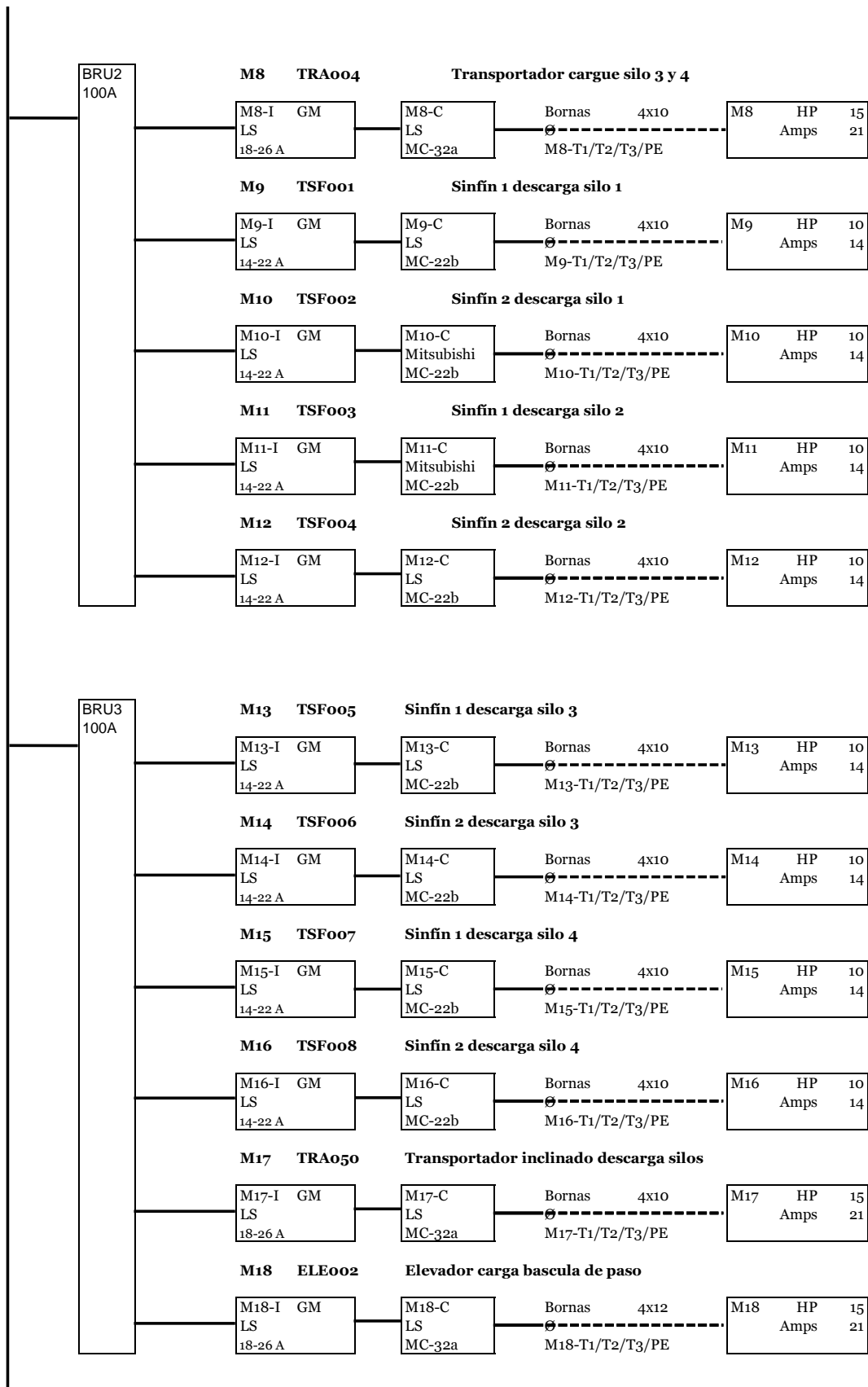

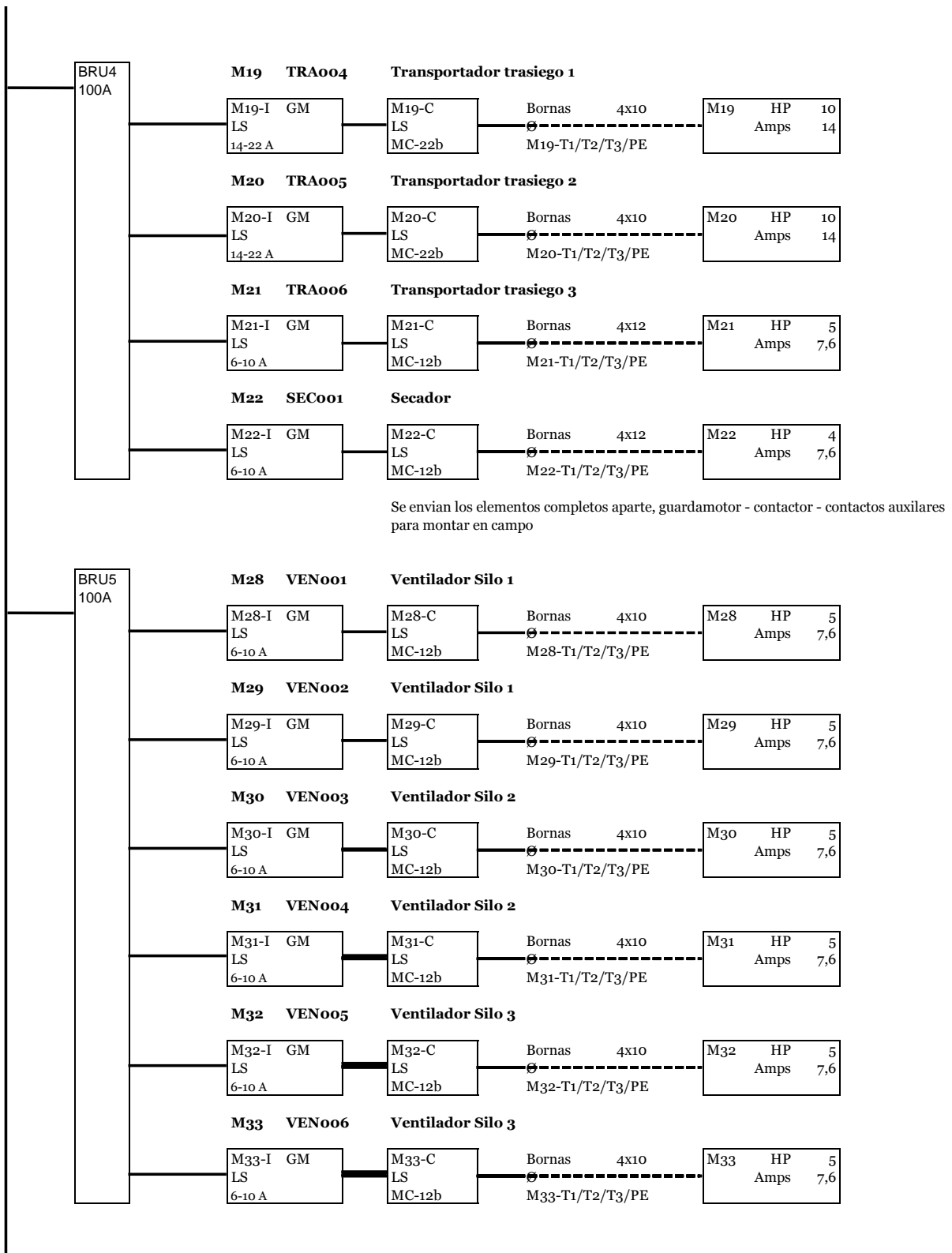

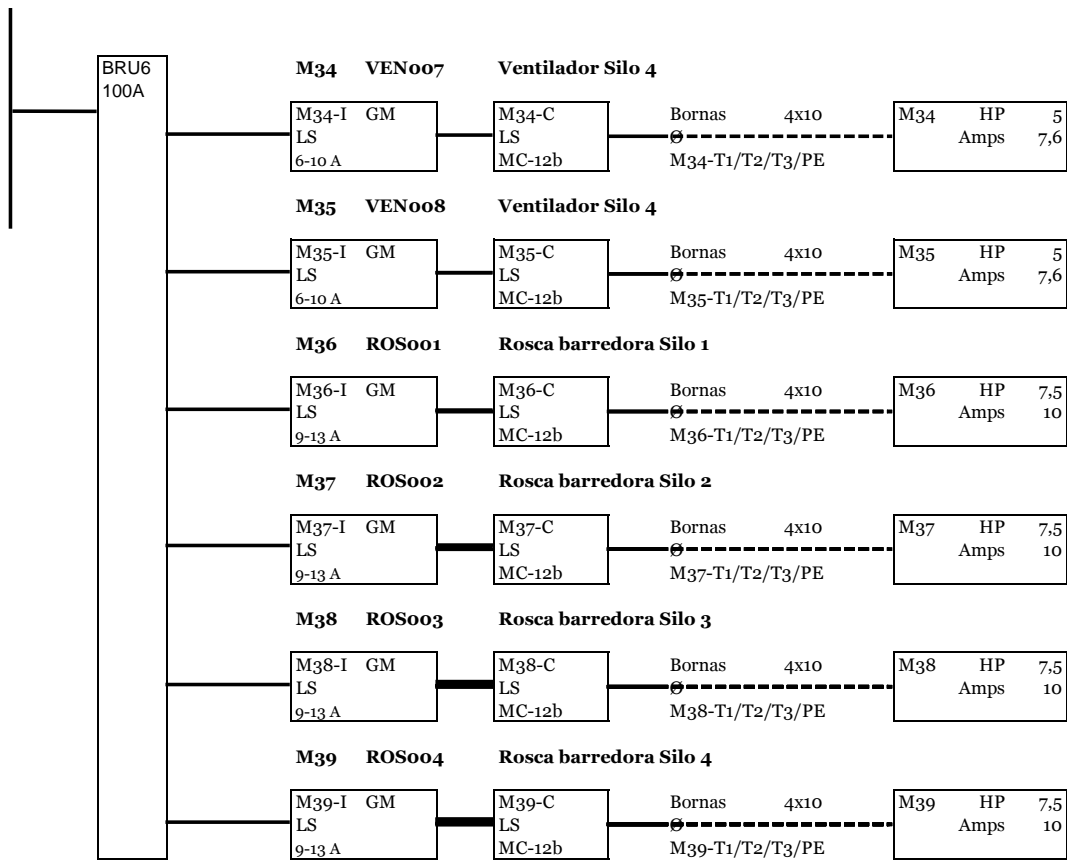

M1 ASP001 Filtro recibo 1

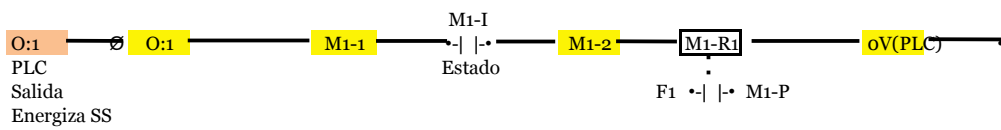
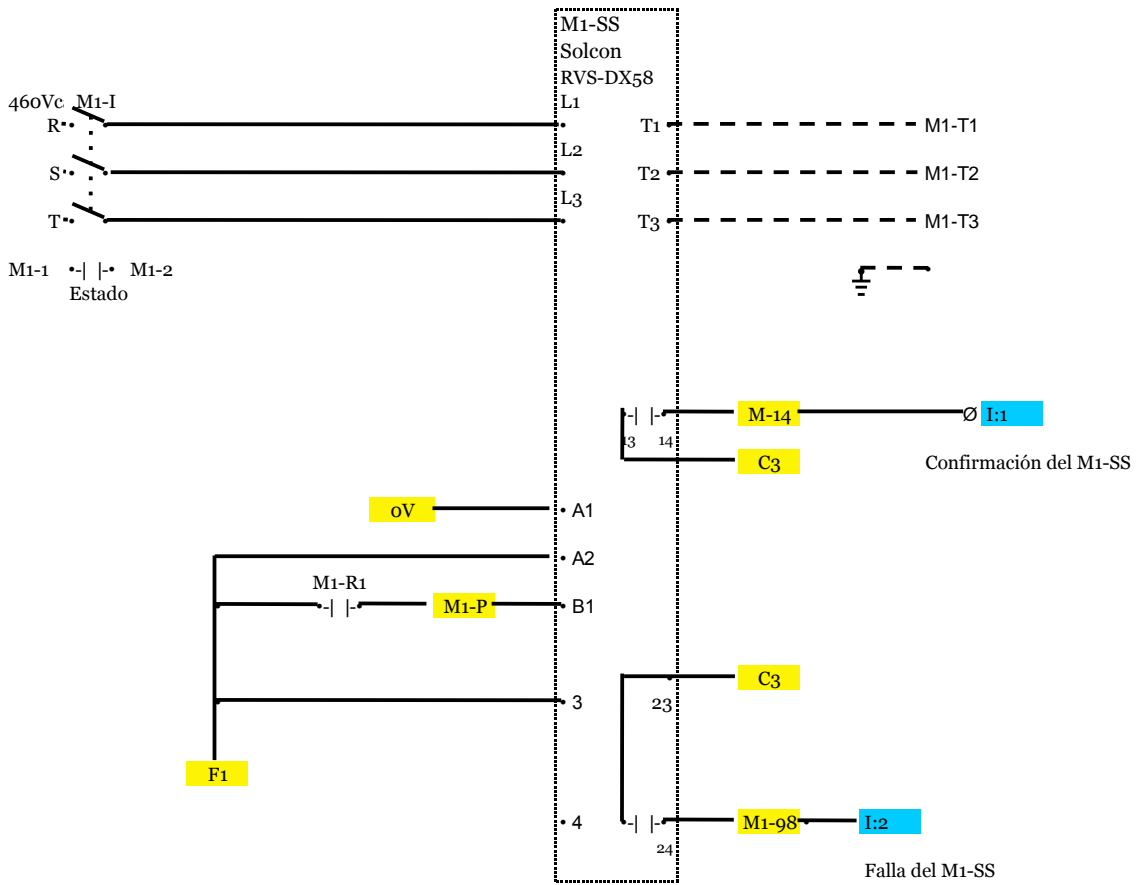

Bornas

M1-T1
M1-T2
M1-T3
M1-PE
O:1
I:1
I:2

PLC- Salida orden para energizar
 PLC- Entrada para confirmación de arranque
 PLC- Entrada para falla del trasportador

M2 ASP002 Filtro recibo 2

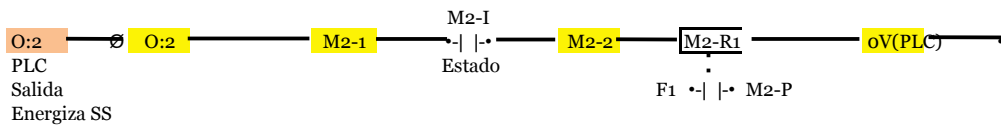
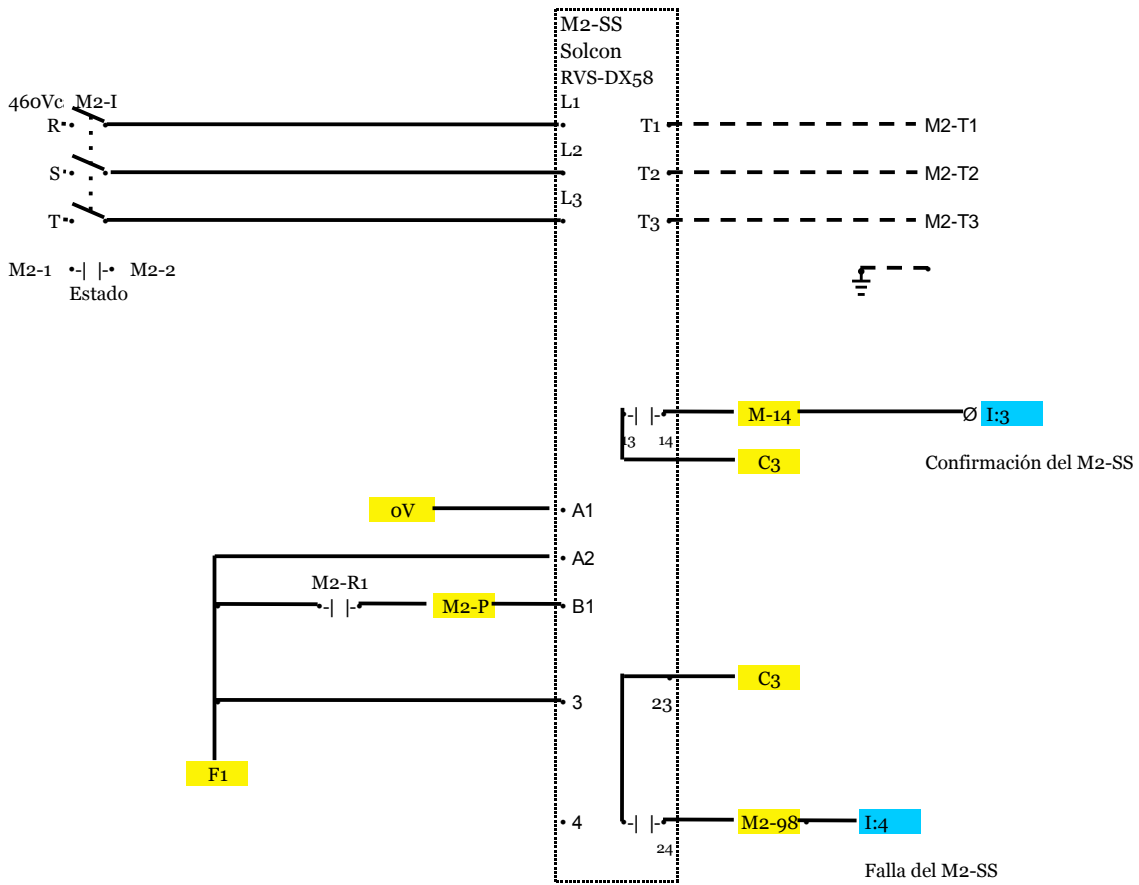

Bornas

M2-T1
M2-T2
M2-T3
M2-PE
O:2
I:3
I:4

PLC- Salida orden para energizar
 PLC- Entrada para confirmación de arranque
 PLC- Entrada para falla del trasportador

M3 PLA001 Plataforma volcadora 001

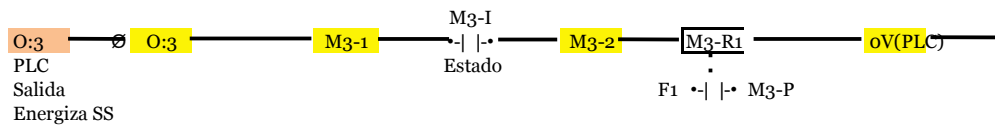
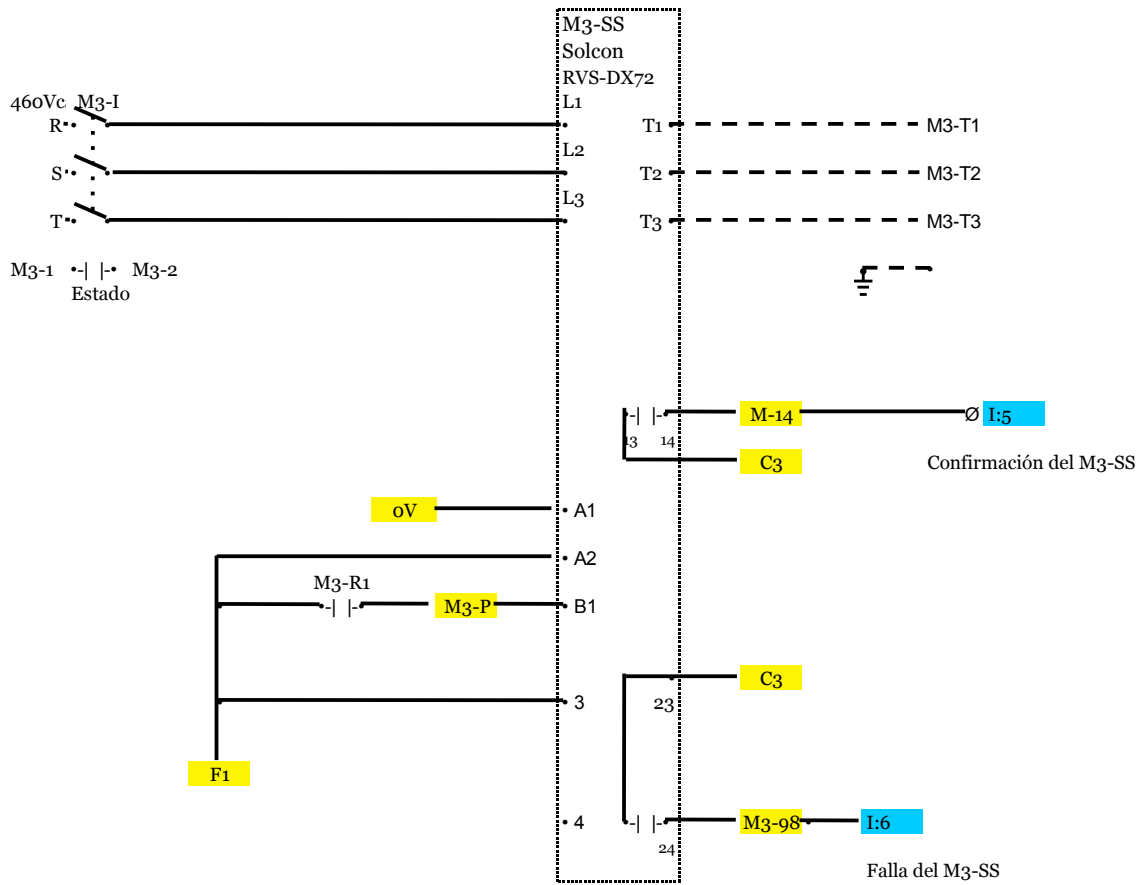

Bornas

M3-T1
M3-T2
M3-T3
M3-PE
O:3
I:5
I:6

PLC- Salida orden para energizar
 PLC- Entrada para confirmación de arranque
 PLC- Entrada para falla del trasportador

M5 ELE001 Elevador tolva recibo

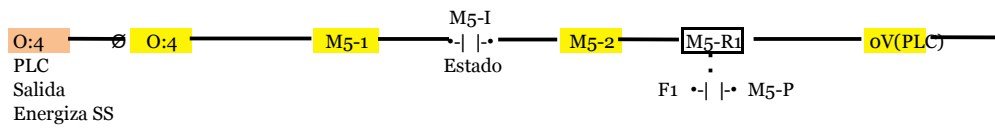
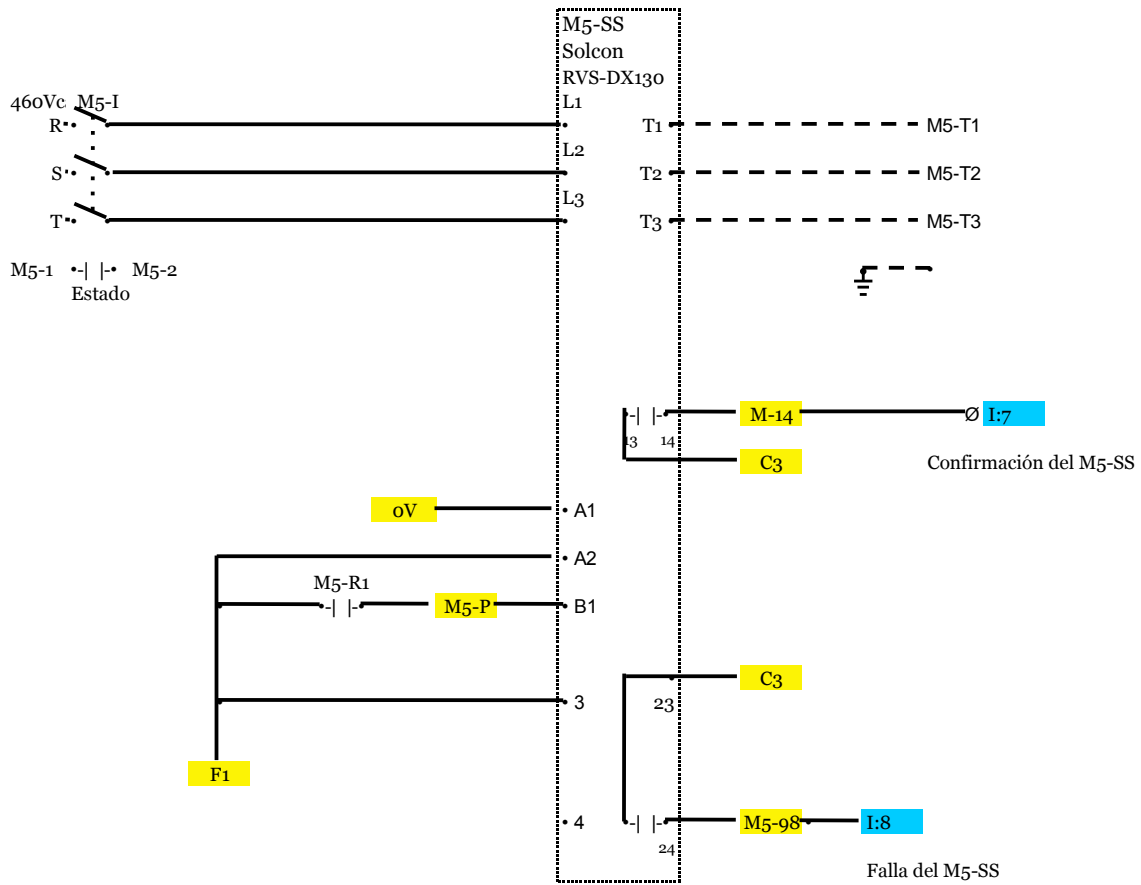

Bornas

M5-T1
M5-T2
M5-T3
M5-PE
O:4
I:7
I:8

PLC- Salida orden para energizar
 PLC- Entrada para confirmación de arranque
 PLC- Entrada para falla del trasportador

M6 TRA002 Transportador cargue 4 silos

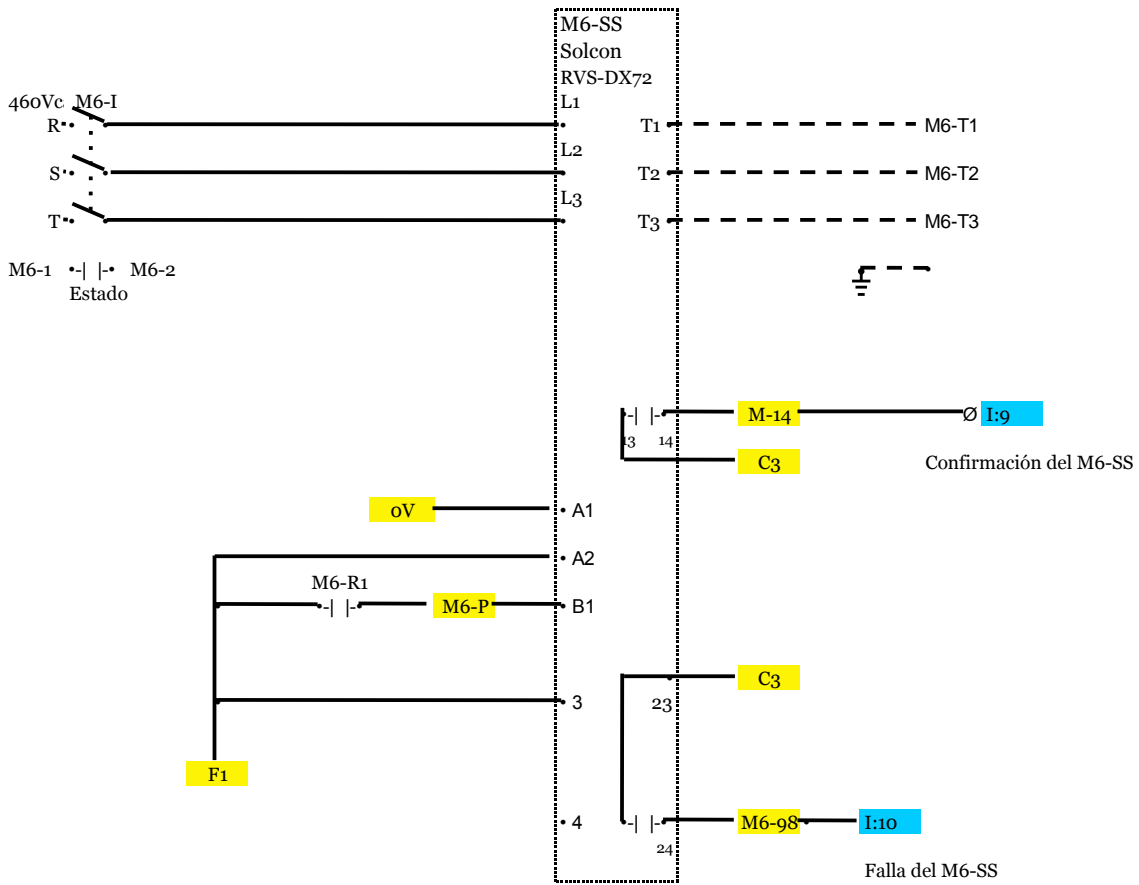

Bornas

M6-T1
M6-T2
M6-T3
M6-PE
O:5
I:9
I:10

PLC- Salida orden para energizar
 PLC- Entrada para confirmación de arranque
 PLC- Entrada para falla del trasportador

M4 TRA001 Transportador tolva recibo

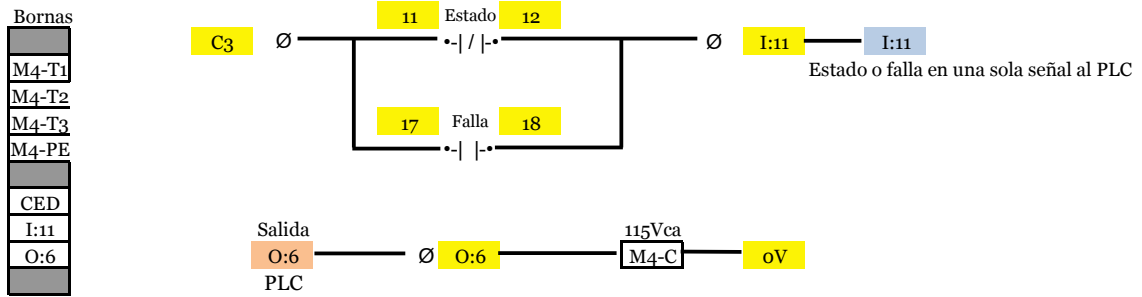
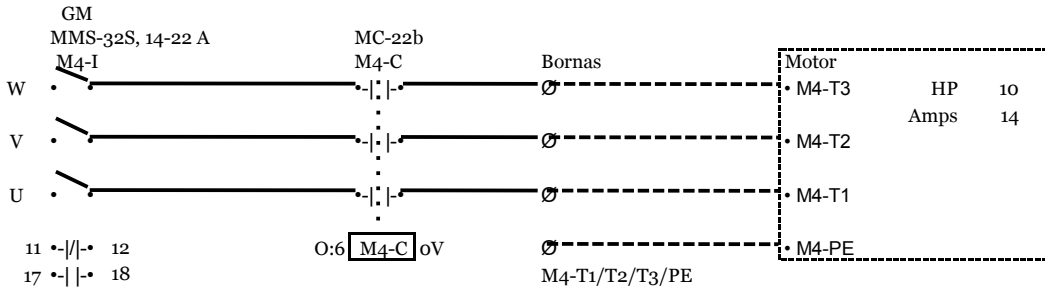

PLC- Salida orden para energizar arrancador

M7 TRA003 Transportador cargue silo 1 y 2

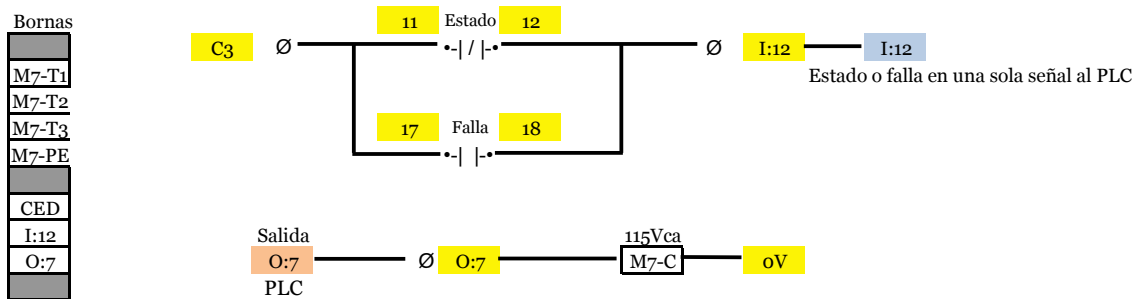
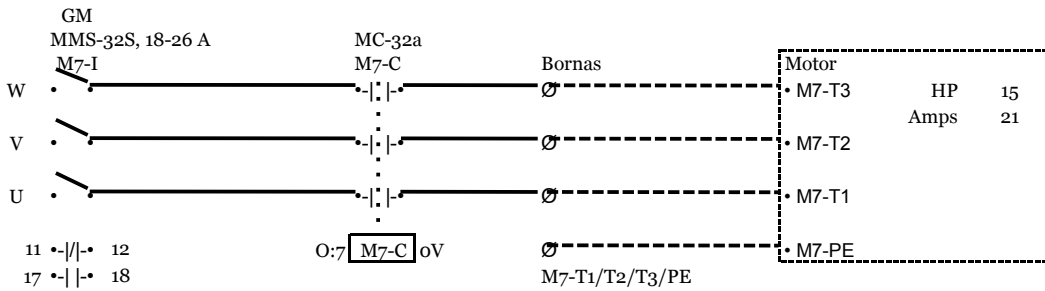

PLC- Salida orden para energizar arrancador

M8 TRA004 Transportador cargue silo 3 y 4

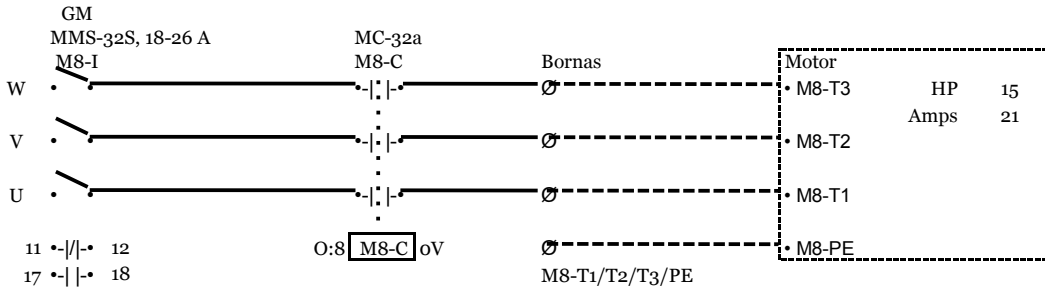

Bornas
M8-T1
M8-T2
M8-T3
M8-PE
CED
I:13
O:8

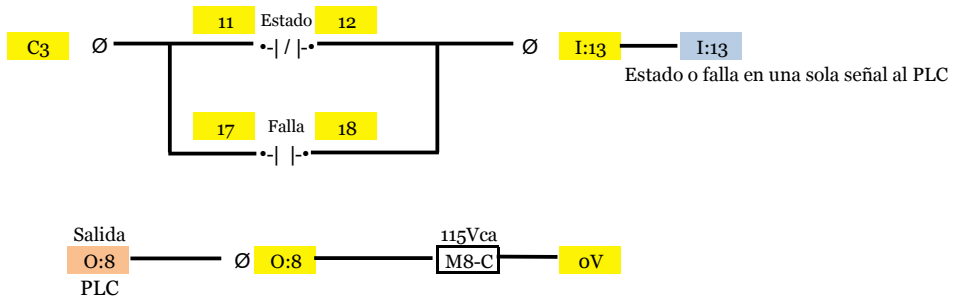

PLC- Salida orden para energizar arrancador

M9 TSF001 Sinfin 1 descarga silo 1

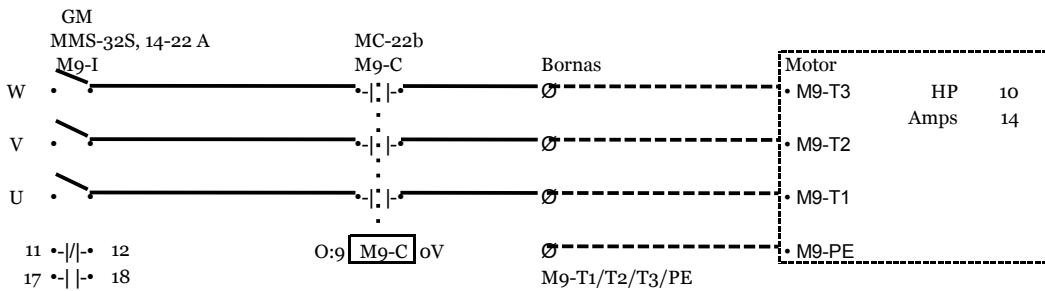

Bornas
M9-T1
M9-T2
M9-T3
M9-PE
CED
I:14
O:9

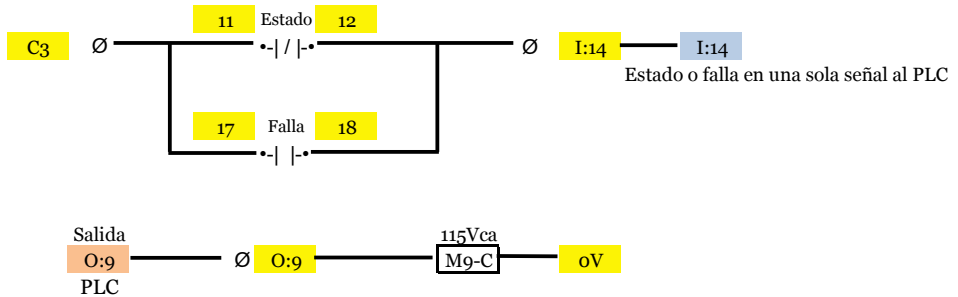

PLC- Salida orden para energizar arrancador

M12 TSF004 Sinfin 2 descarga silo 2

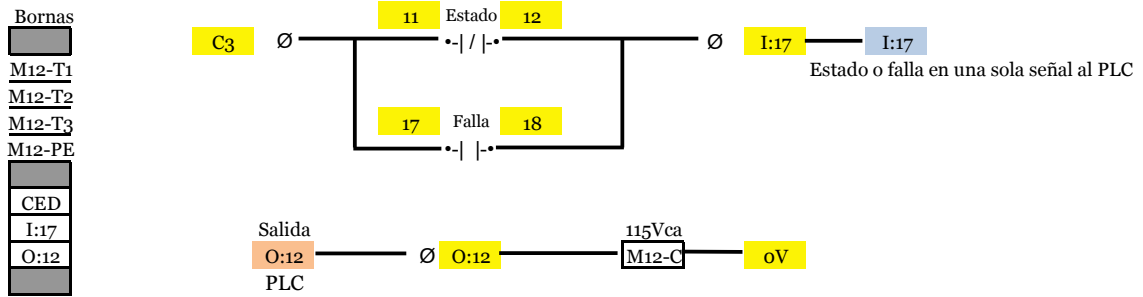
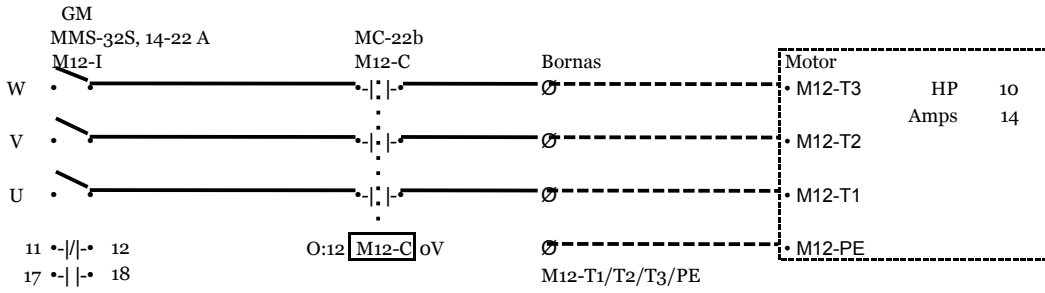

PLC- Salida orden para energizar arrancador

M13 TSF005 Sinfin 1 descarga silo 3

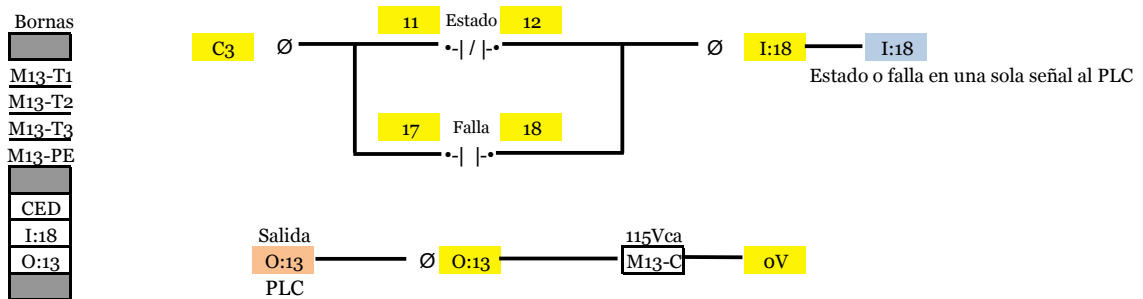
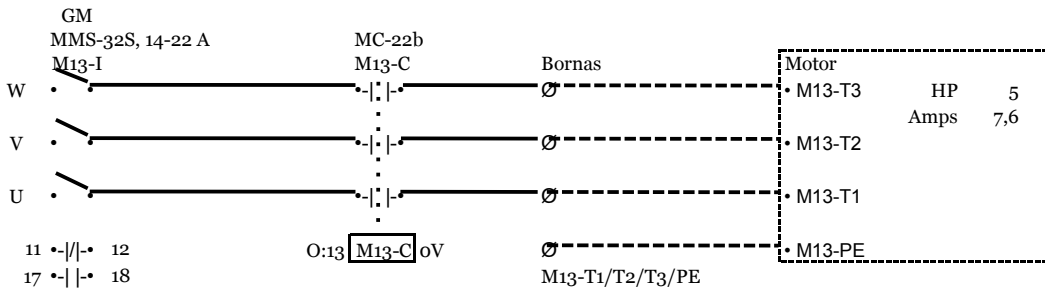

PLC- Salida orden para energizar arrancador

M14 TSFoo6 Sinfin 2 descarga silo 3

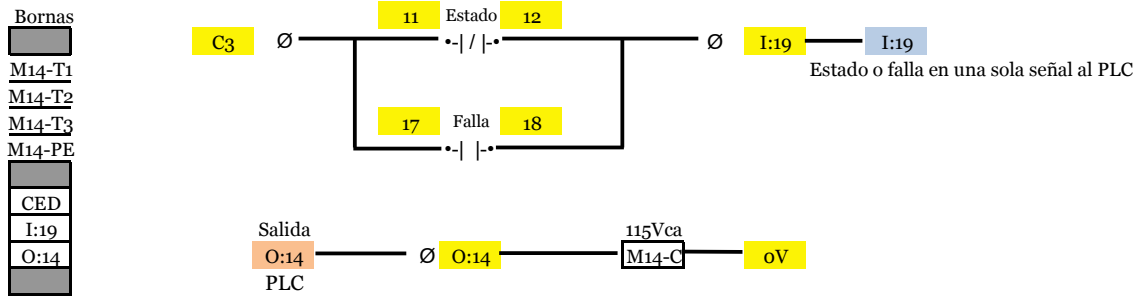
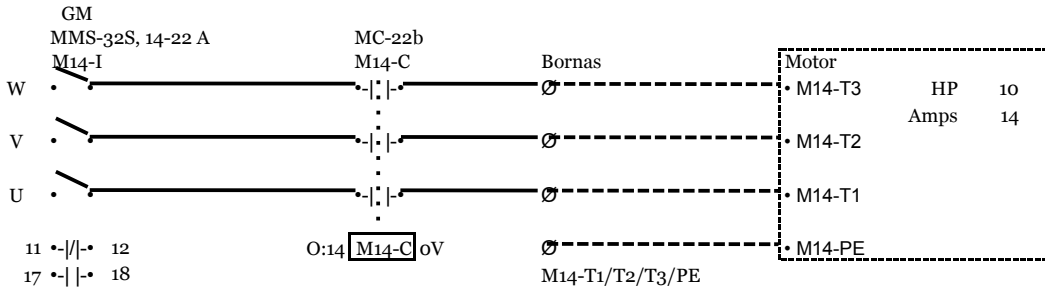

PLC- Salida orden para energizar arrancador

M15 TSFoo7 Sinfin 1 descarga silo 4

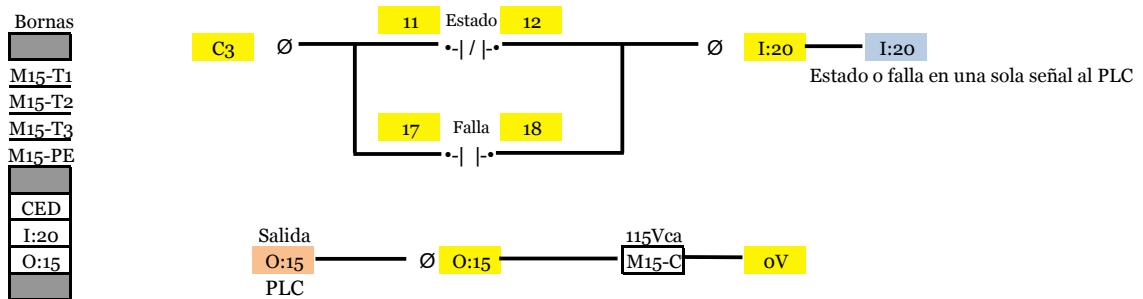
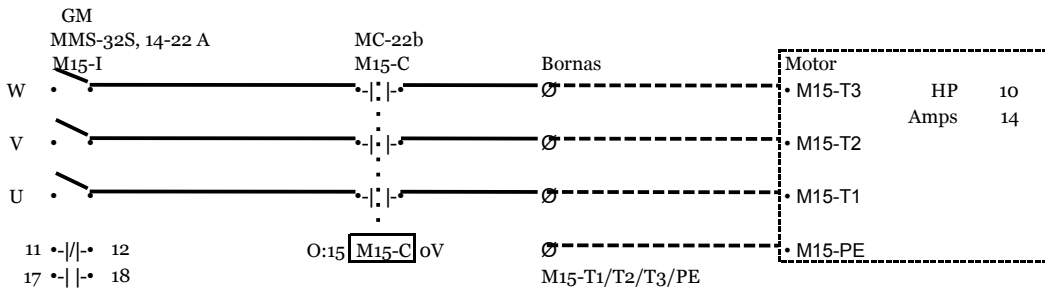

PLC- Salida orden para energizar arrancador

M16 TSFoo8 Sinfin 2 descarga silo 4

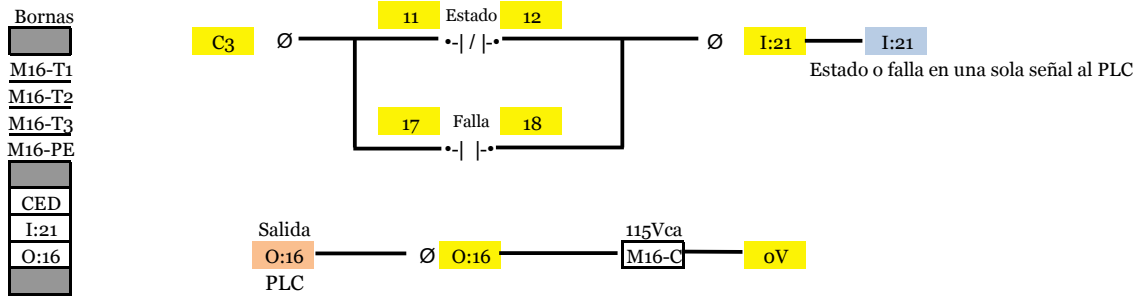
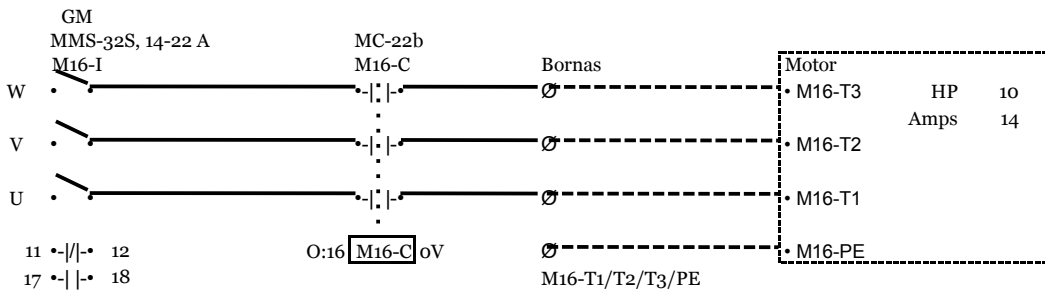

PLC- Salida orden para energizar arrancador

M17 TRA050 Transportador inclinado descarga silos

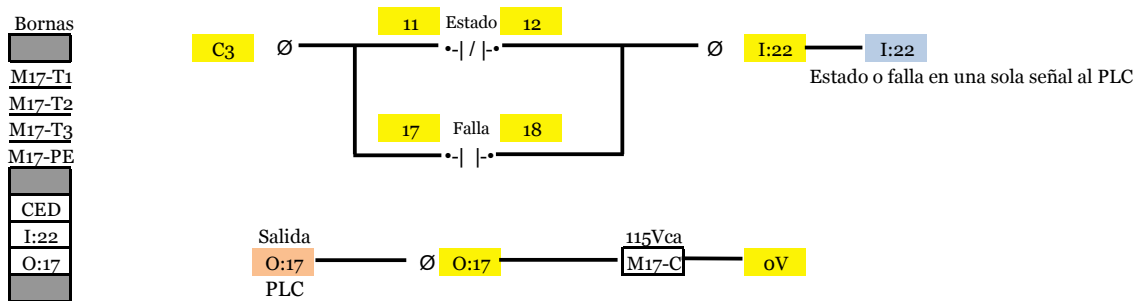
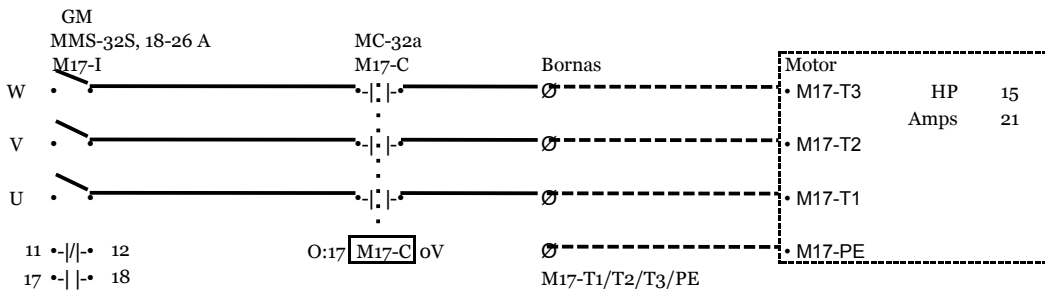

PLC- Salida orden para energizar arrancador

M18 ELE002 Elevador carga bascula de paso

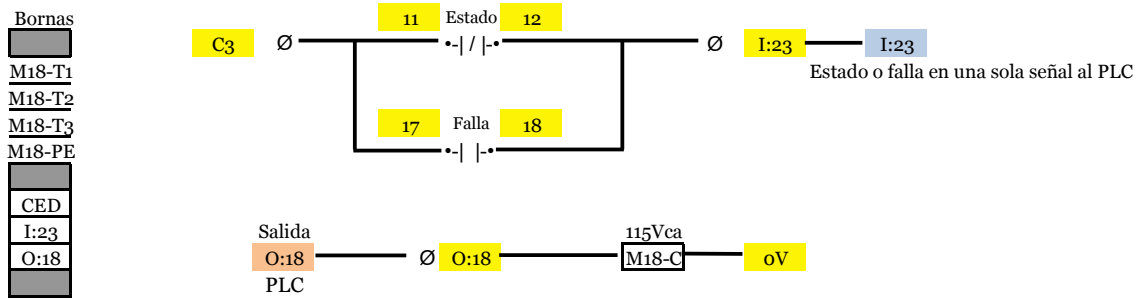
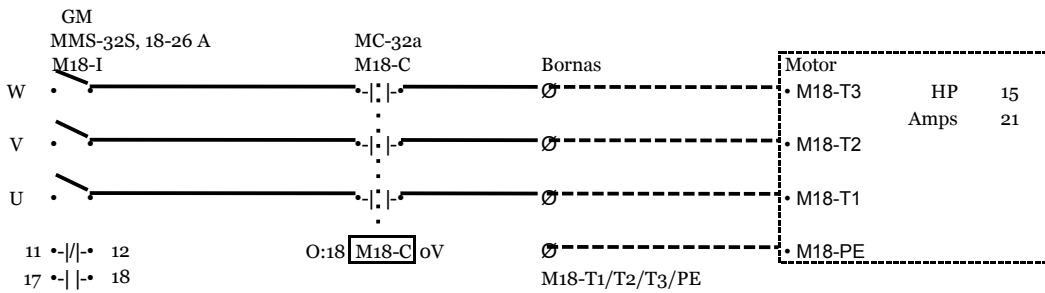

PLC- Salida orden para energizar arrancador

M19 TRA004 Transportador trasiego 1

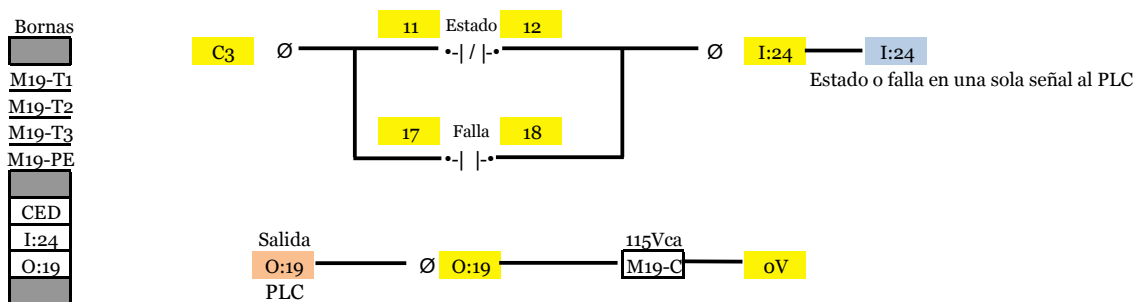
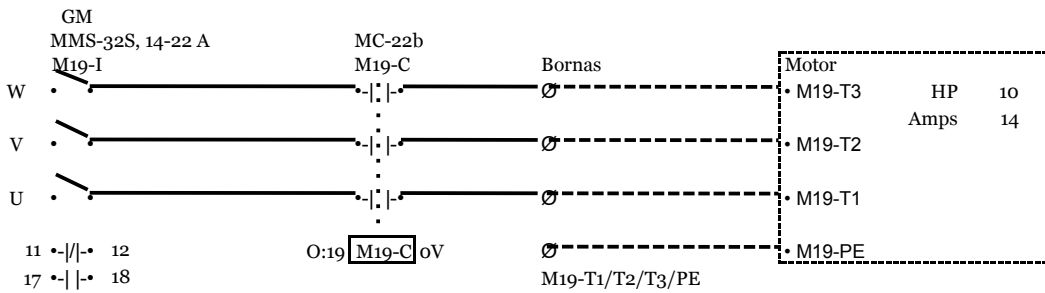

PLC- Salida orden para energizar arrancador

M28 VEN001 Ventilador Silo 1

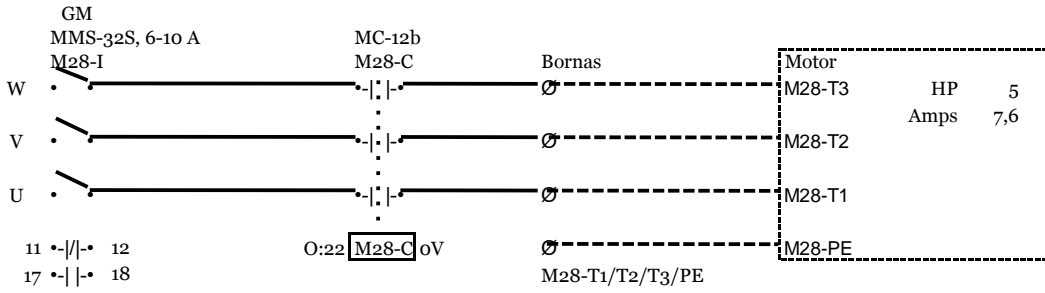

Bornas
M28-T1
M28-T2
M28-T3
M28-PE
CED
I:27
O:22

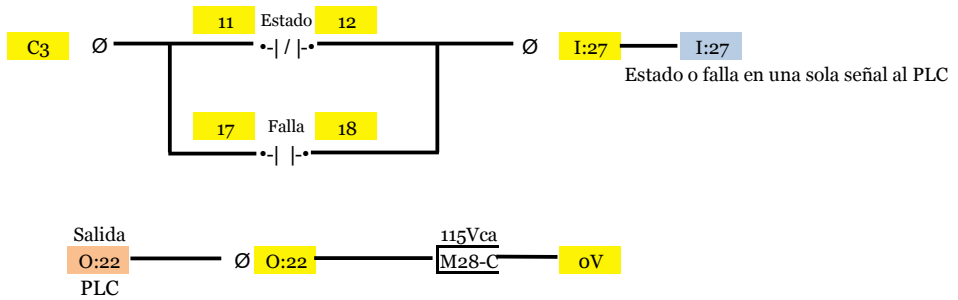

PLC- Salida orden para energizar arrancador

M29 VEN002 Ventilador Silo 1

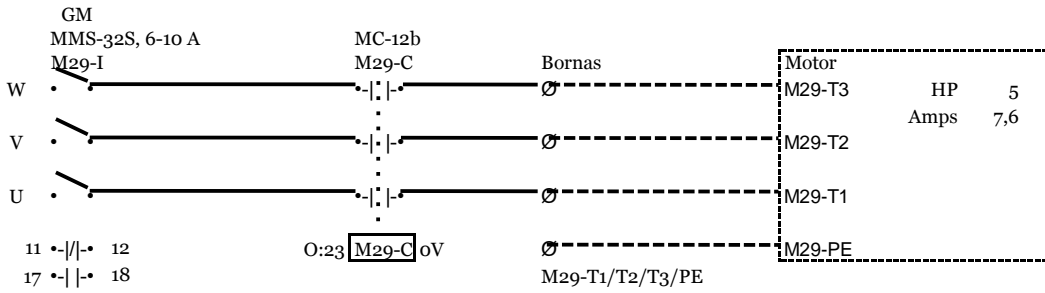

Bornas
M29-T1
M29-T2
M29-T3
M29-PE
CED
I:28
O:23

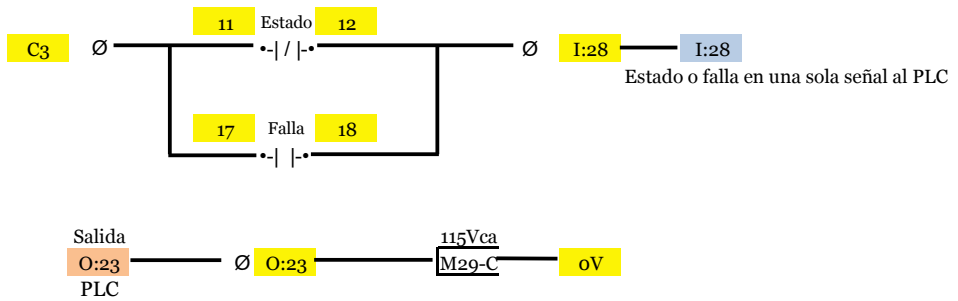

PLC- Salida orden para energizar arrancador

M30 VEN003 Ventilador Silo 2

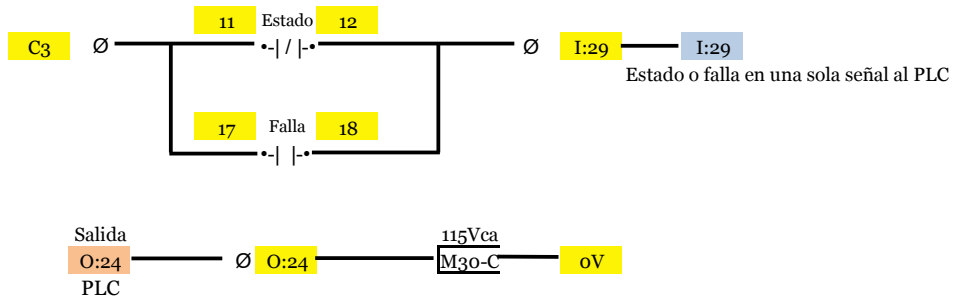
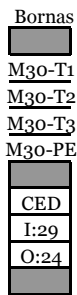
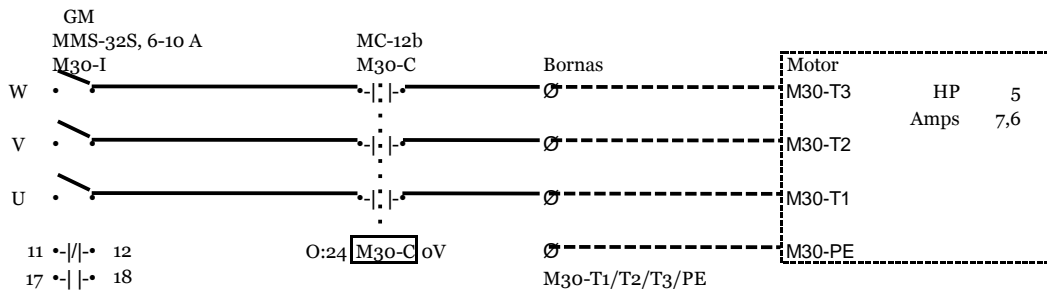

PLC- Salida orden para energizar arrancador

M31 VEN004 Ventilador Silo 2

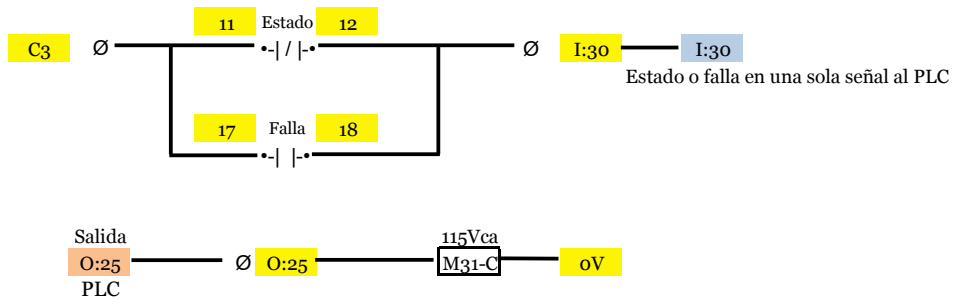
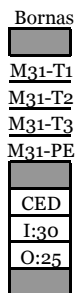
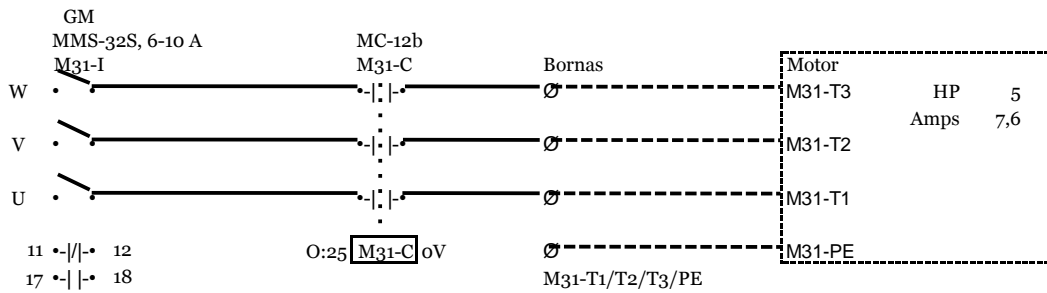

PLC- Salida orden para energizar arrancador

M32 VEN005 Ventilador Silo 3

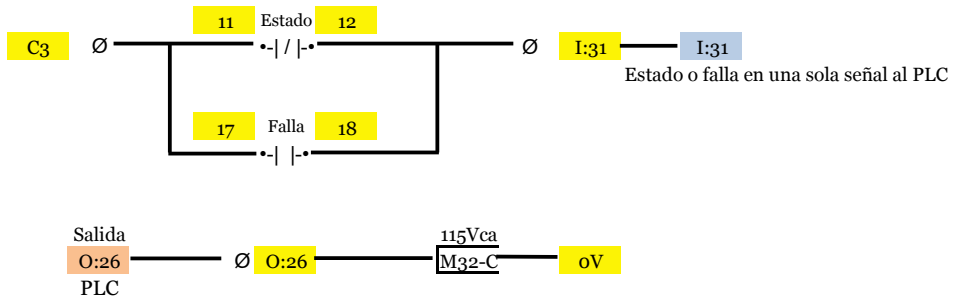
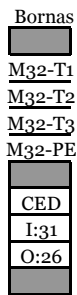
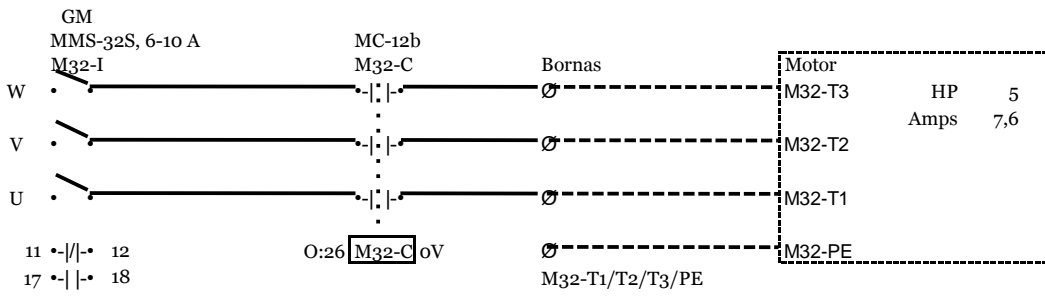

PLC- Salida orden para energizar arrancador

M33 VEN006 Ventilador Silo 3

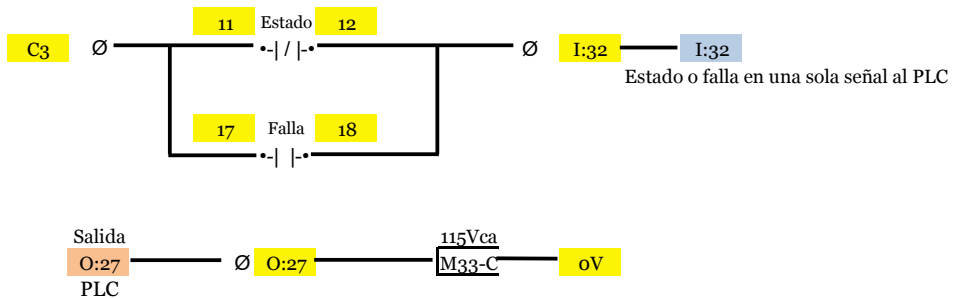
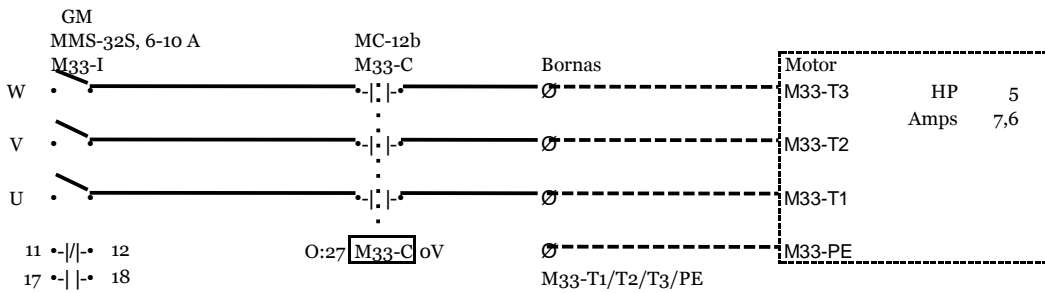

PLC- Salida orden para energizar arrancador

M34 VEN007 Ventilador Silo 4

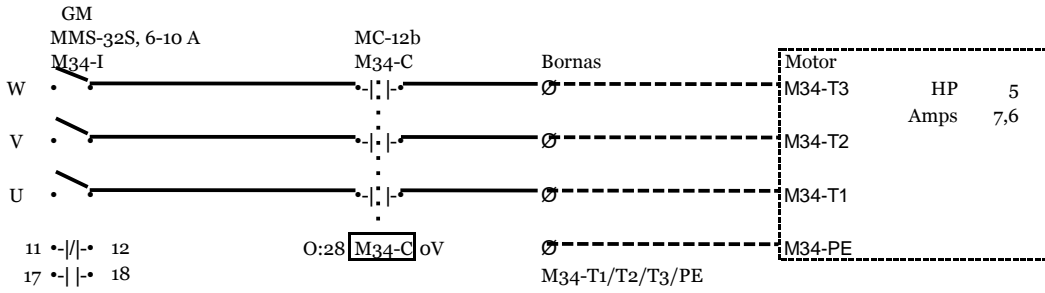

Bornas
M34-T1
M34-T2
M34-T3
M34-PE
CED
I:33
O:28

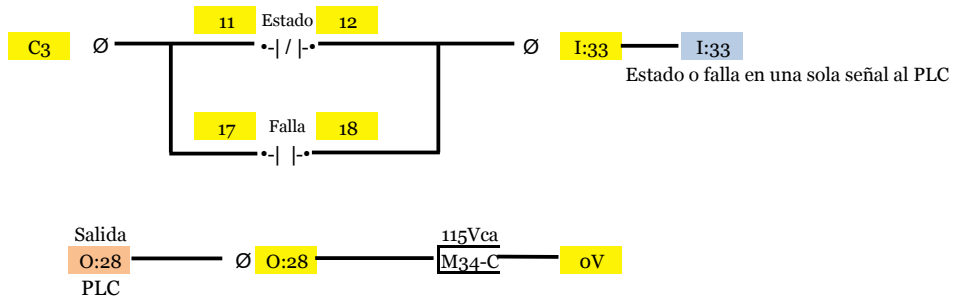

PLC- Salida orden para energizar arrancador

M35 VEN008 Ventilador Silo 4

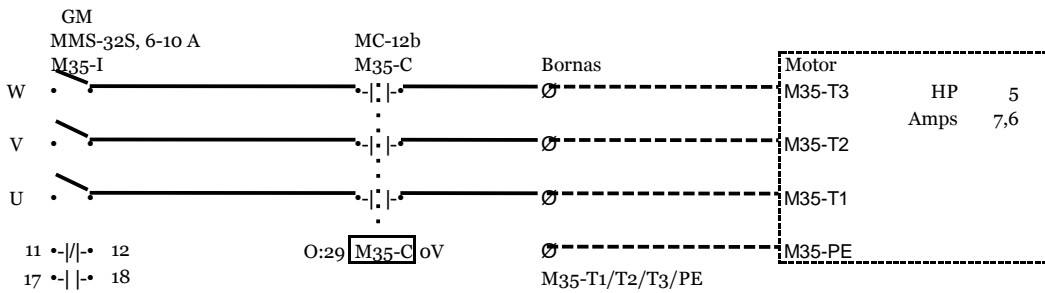

Bornas
M35-T1
M35-T2
M35-T3
M35-PE
CED
I:34
O:29

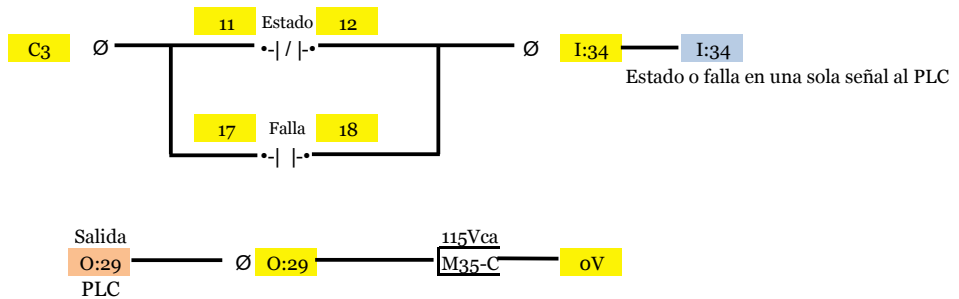

PLC- Salida orden para energizar arrancador

M36 ROS001 Rosca barredora Silo 1

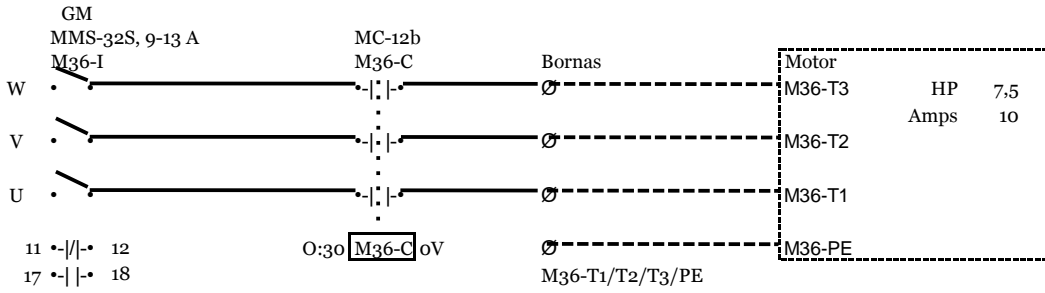

Bornas
M36-T1
M36-T2
M36-T3
M36-PE
CED
I:35
O:30

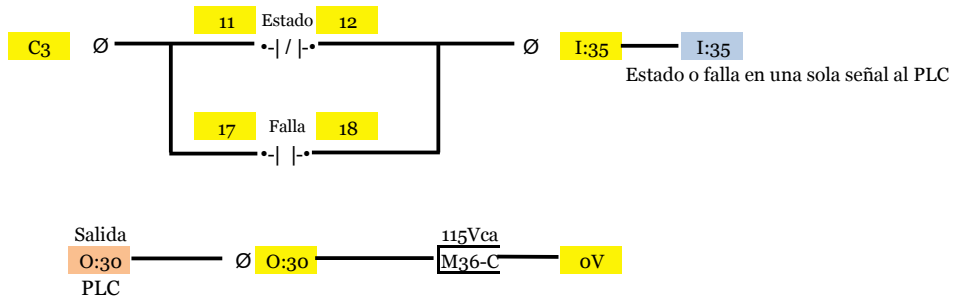

PLC- Salida orden para energizar arrancador

M37 ROS002 Rosca barredora Silo 2

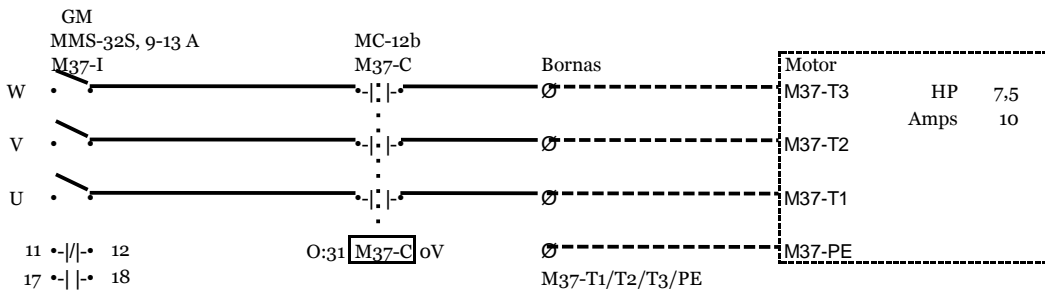

Bornas
M37-T1
M37-T2
M37-T3
M37-PE
CED
I:36
O:31

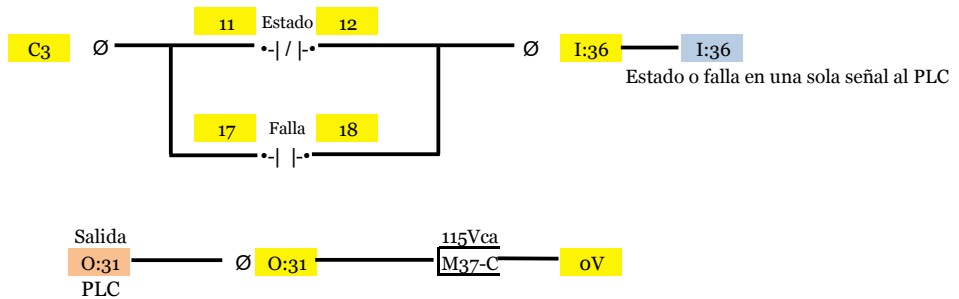

PLC- Salida orden para energizar arrancador

3 Fases - 460Vca - 36 Ka

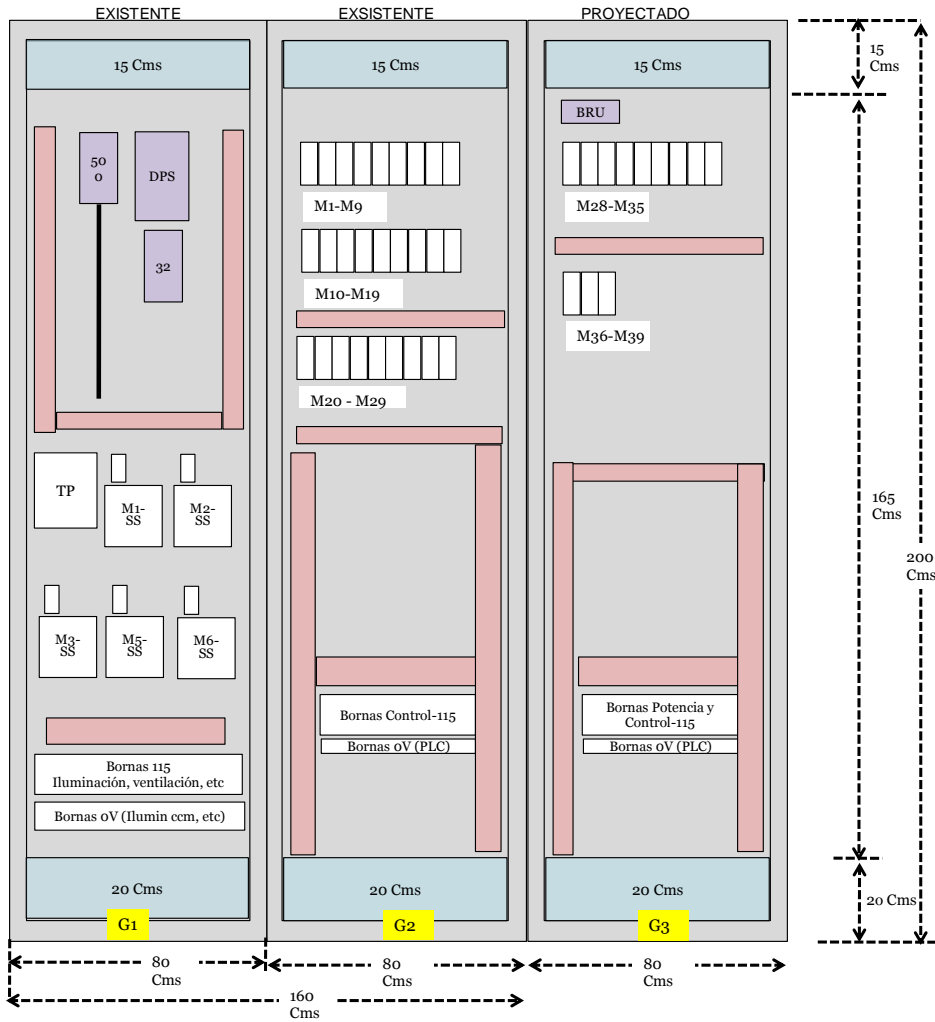

Dimensiones en metros	G1	G2	G3	m ²	Kg
Altura	2,0	2,0	2,0	21,6	325
Ancho	0,8	0,8	0,8	2,4	
Profundidad	0,6	0,6	0,6		
Lámina perfiles	14	14	14		
Lámina tapas y puertas	16	16	16		
IP	65	65			

Color RAL 7032

Pueden distribuir los espacios como consideren necesario respecto al tamaño de los equipos, si se tiene que crecer el tamaño del CCM también se puede hacer
 Los dos gabinetes se pueden ir ensamblados
 Atención al huacal

3 Fases - 460Vca - 36 Ka

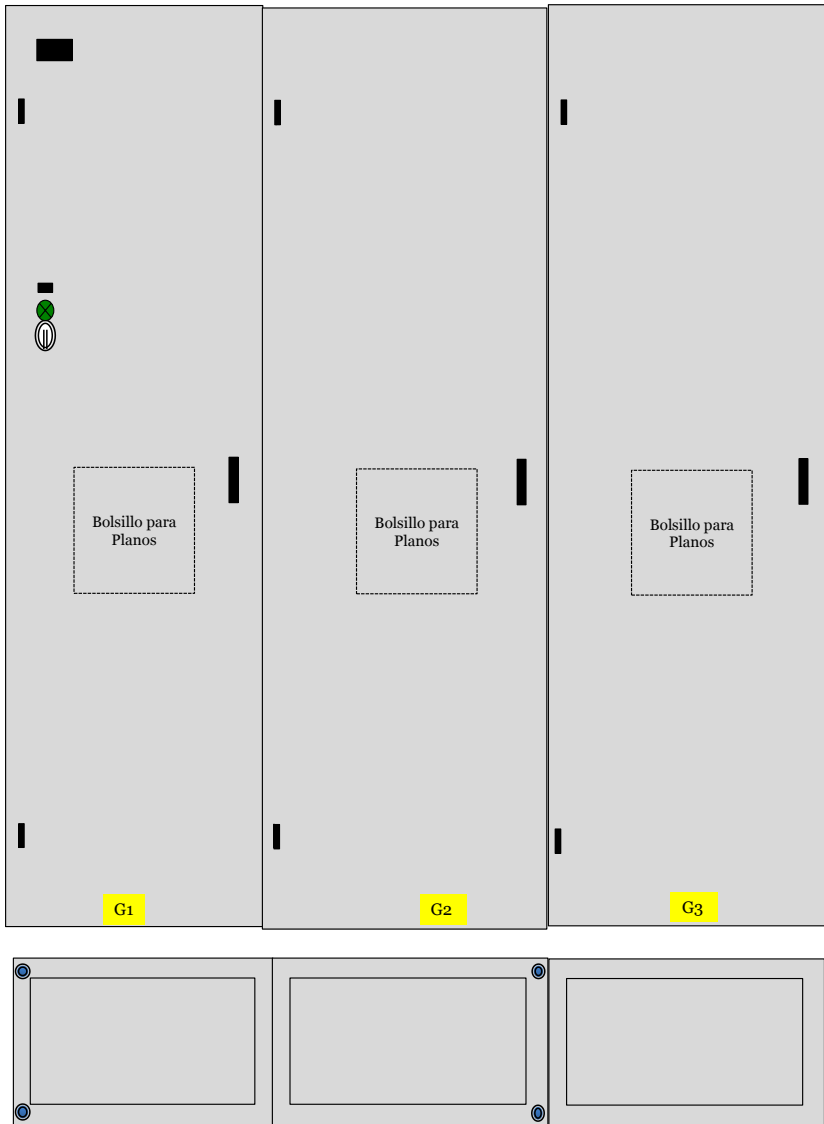

4 Argollas para descargue y descargue
El tablero debe ir completamente ensamblado

Nota

Utilizar el espacio disponible lo mas compacto y eficiente posible con el fin de tener espacio por si se requieren equipos adicionales