

**DIAGRAMA - CENTRO DE CONTROL DE MOTORES CCM-5 - 3FASES 460Vca- 25 Ka**

Todos los arrancadores suaves serán marca Eaton  
 Los contactores serán, Guardamotores e Interruptores Marca LSIS

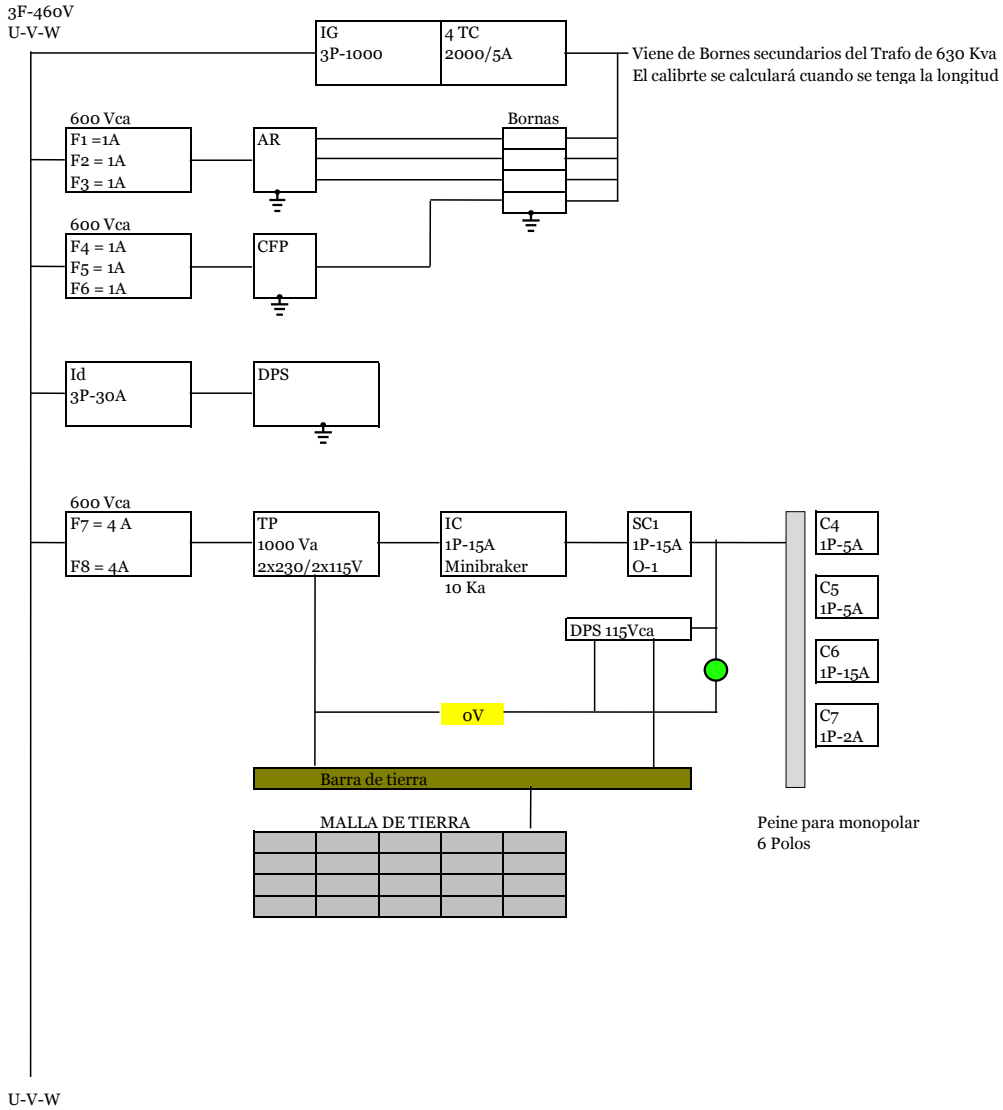

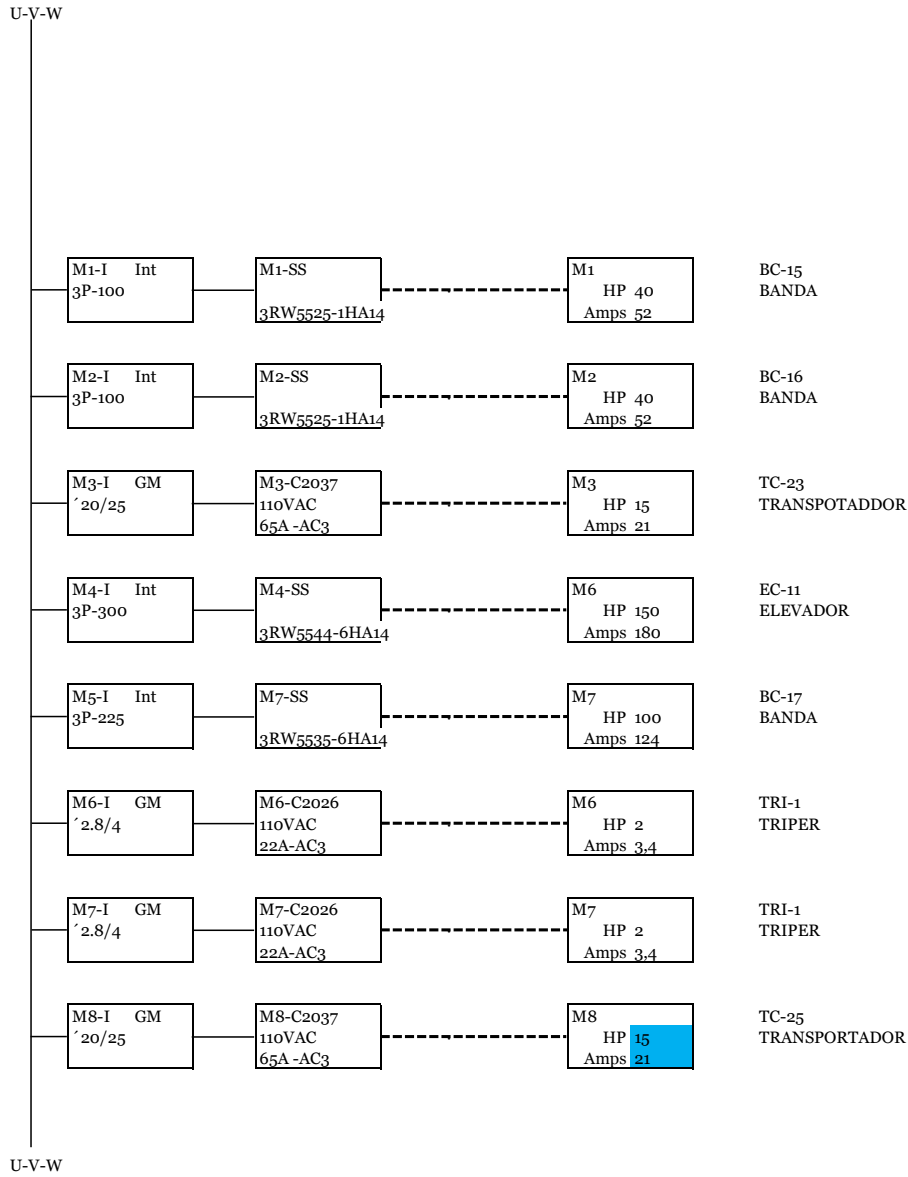

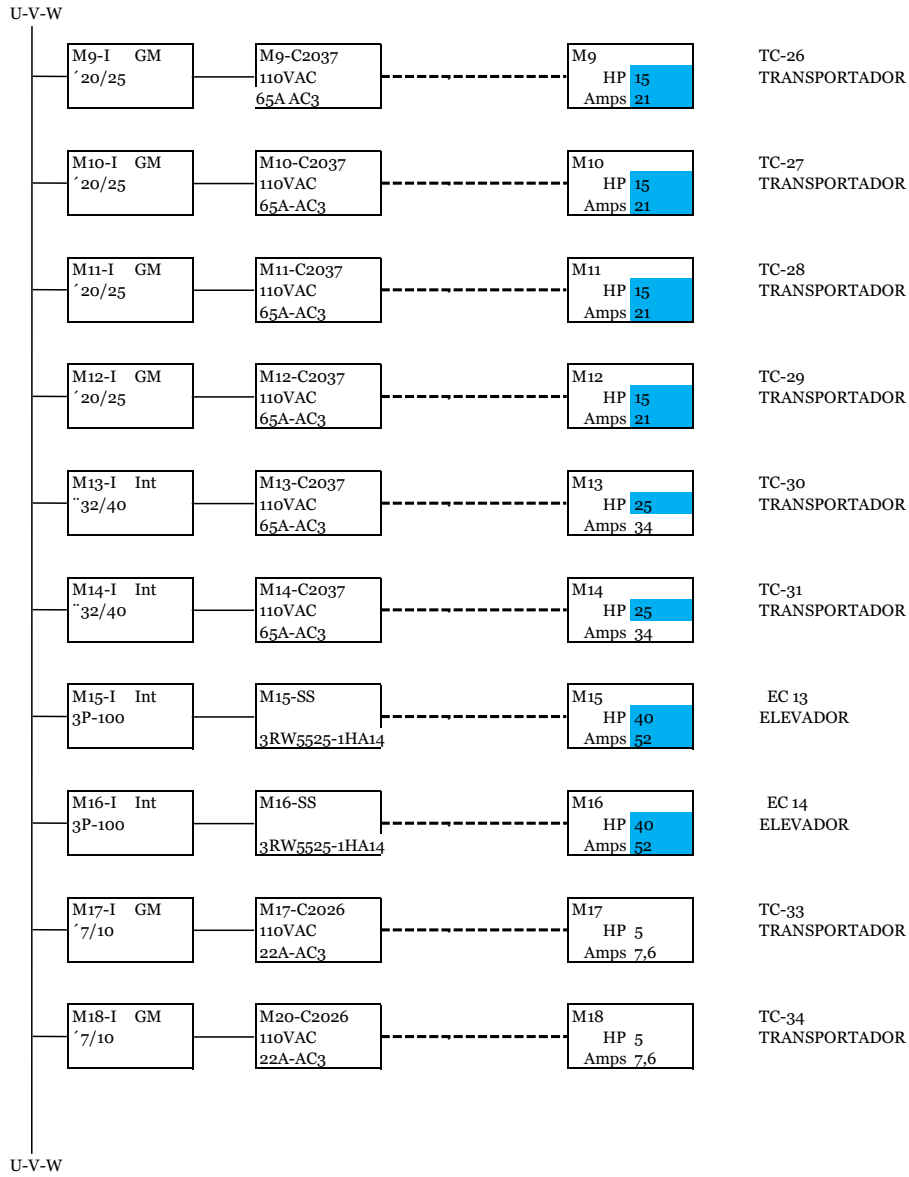

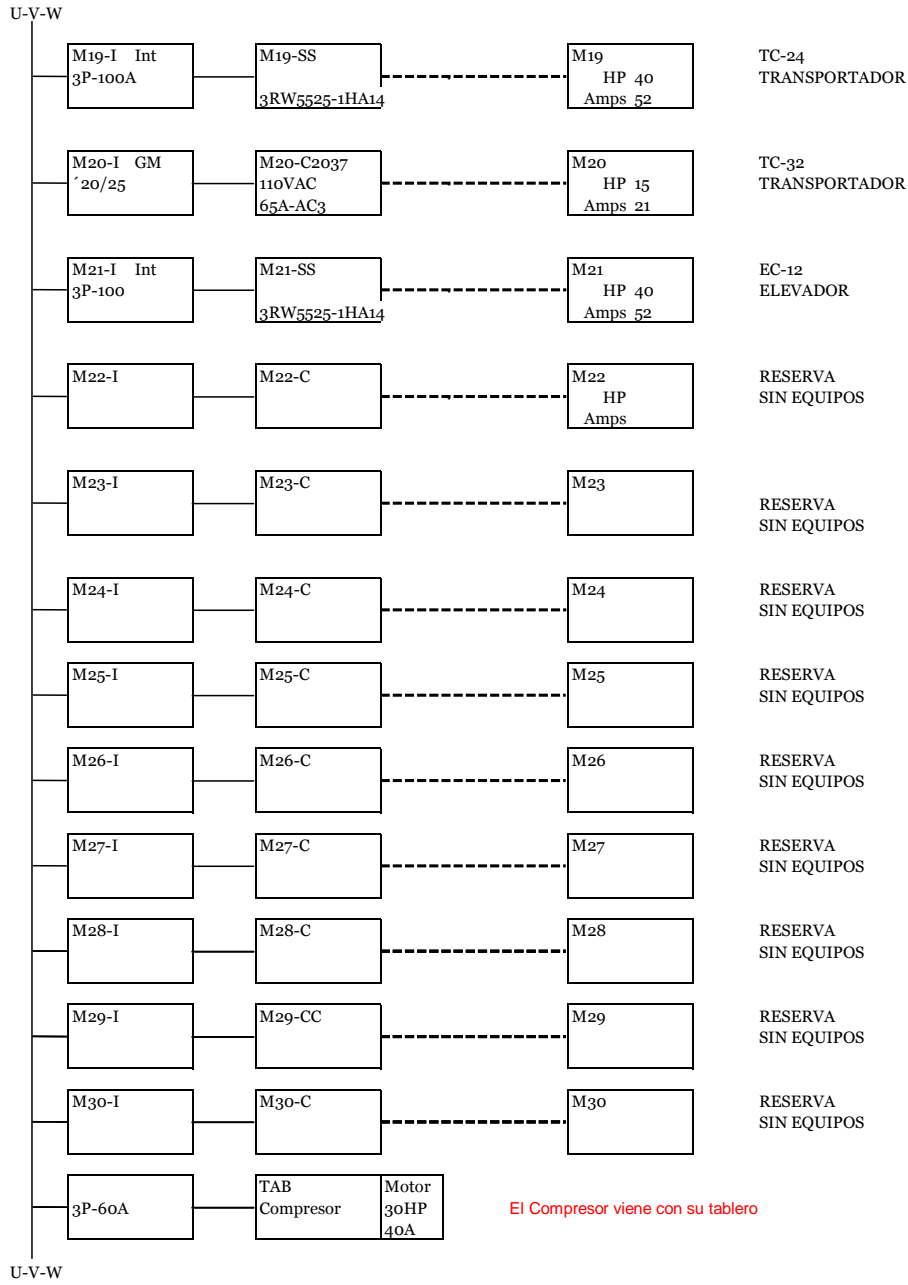

# Motor	CODIGO	EQUIPO	HP	Amp-P	Amps	Kva	Amps SS	ef.SS-Siemens	Int-Siemens
M1	BC 15	TRANSPORTADOR DE BANDA 15	40,0	52,0	59,8	48	66	3RW5525-1F	84
M2	BC 16	TRANSPORTADOR DE BANDA 16	40,0	52,0	59,8	48	66	3RW5525-1F	84
M3	TC 23	TRANSPORTADOR DE CADENA 23	15,0	21,0	24,2	19	27	65A AC3	20/25
M4	EC 11	ELEVADOR DE CANGILONES 11	150,0	180,0	207,0	165	228	3RW5544-6	290
M5	BC 17	TRANSPORTADOR DE BANDA 17	100,0	124,0	142,6	113	157	3RW5535-6I	200
M6	TRI-1	TRIPPER SILO 5	2,0	3,4	3,9	3	4	22A AC3	2.8/4
M7	TRI-2	TRIPPER SILO 6	2,0	3,4	3,9	3	4	22A AC3	2.8/4
M8	TC 25	TRANSPORTADOR DE CADENA 25	15,0	21,0	24,2	19	27	65A AC3	20/25
M9	TC 26	TRANSPORTADOR DE CADENA 26	15,0	21,0	24,2	19	27	65A AC3	20/25
M10	TC 27	TRANSPORTADOR DE CADENA 27	15,0	21,0	24,2	19	27	65A AC3	20/25
M11	TC 28	TRANSPORTADOR DE CADENA 28	15,0	21,0	24,2	19	27	65A AC3	20/25
M12	TC 29	TRANSPORTADOR DE CADENA 29	15,0	21,0	24,2	19	27	65A AC3	20/25
M13	TC 30	TRANSPORTADOR DE CADENA 30	25,0	34,0	39,1	31	43	65A AC3	34/40
M14	TC 31	TRANSPORTADOR DE CADENA 31	25,0	34,0	39,1	31	43	65A AC3	34/40
M15	EC 13	ELEVADOR DE CANGILONES 13	40,0	52,0	59,8	48	66	3RW5525-1F	84
M16	EC 14	ELEVADOR DE CANGILONES 14	40,0	52,0	59,8	48	66	3RW5525-1F	84
M17	TC 33	TRANSPORTADOR DE CADENA 33	5,0	7,6	8,7	10	10	22A AC3	7/10
M18	TC 34	TRANSPORTADOR DE CADENA 34	5,0	7,6	8,7	10	10	22A AC3	7/10
M19	TC 24	TRANSPORTADOR DE CADENA 24	40,0	52,0	59,8	48	66	3RW5525-1F	84
M20	TC 32	TRANSPORTADOR DE CADENA 32	15,0	21,0	24,2	19	27	65A AC3	20/25
M21	EC 12	ELEVADOR DE CANGILONES 12	40,0	52,0	59,8	48	66	3RW5525-1F	84

**FUTUROS MOTORES PARA 3 SILOS- SE DEJAN ESPACIOS SIN EQUIPOS**

# Motor	CODIGO	EQUIPO	HP	Amp-P	Amps	Kva	Amps SS	ef.SS-Siemens	Int-Siemens	Espacio Cms	Cable
M22		Banda de Elevador a Banda sobre silos	75	96,0	110,4	88	121	3RW5534-6I	155		
M23		Banda sobre silos	100	124,0	142,6	113	157	3RW5535-6I	200		
M24		Triper 1	2	3,4	3,9	3	4	22A AC3	2.8/4		
M25		Triper 2	2	3,4	3,9	3	4	22A AC3	2.8/4		
M26		Transportador descarga silo 8	15	21,0	24,2	19	27	65A AC3	20/25		
M27		Transportador descarga silo 9	15	21,0	24,2	19	27	65A AC3	20/25		
M28		Transportador descarga silo 10	15	21,0	24,2	19	27	65A AC3	20/25		
M29		Reserva									
M30		Reserva									

**TRANSFORMADOR PARA CONTROL PARA CCM-5S**

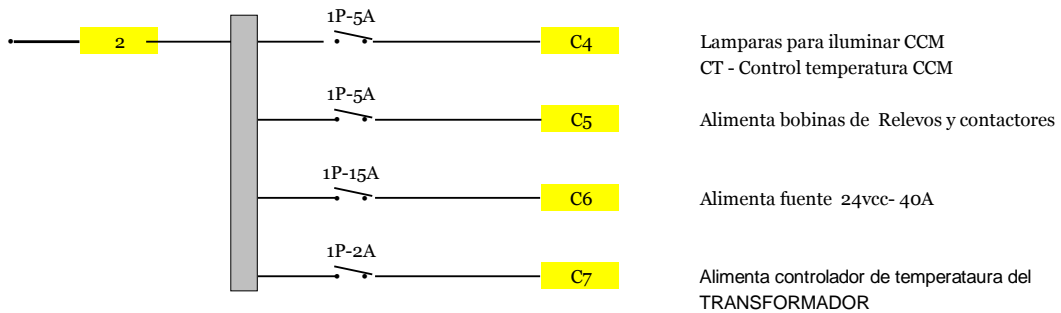
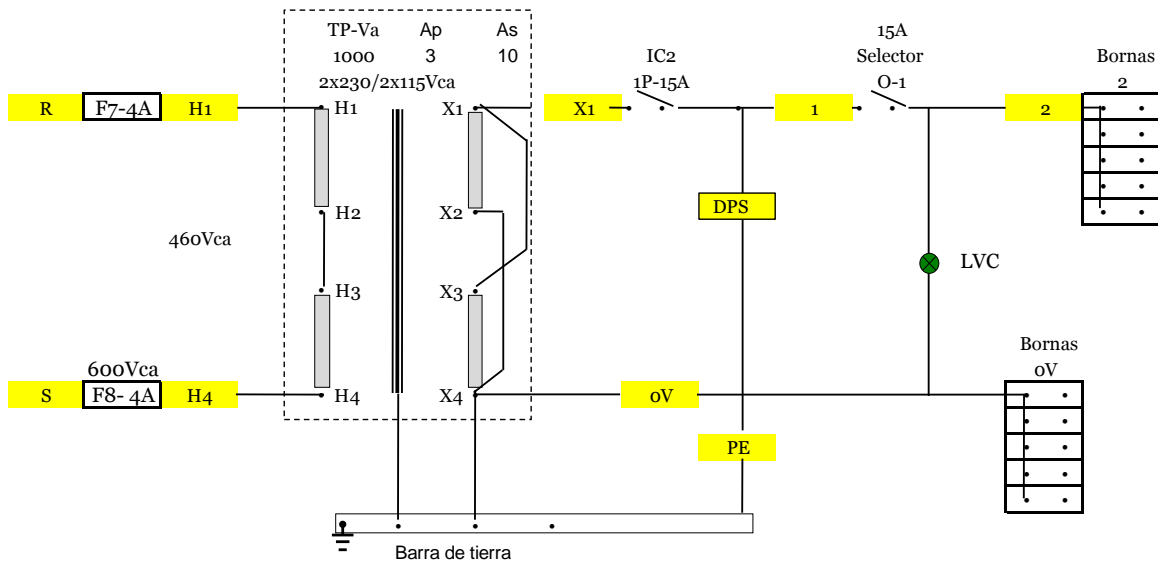

- TP Transformador para control NN Va - Voltaje primario (2 devanados cada uno para 230 Vca)  
Voltaje secundario ( 2 devanados cada uno para 115 Vca)-  
Debe llevar pantalla electrostática para conectar a tierra
- Move DPS- LEVINTON 5280-W
- LVC Luz verde - Indica que hay voltaje para control
- O-1 Selector 10A , instalado en la puerta del CCM - Habilita el control.

**ILUMINACION DE GABINETES**

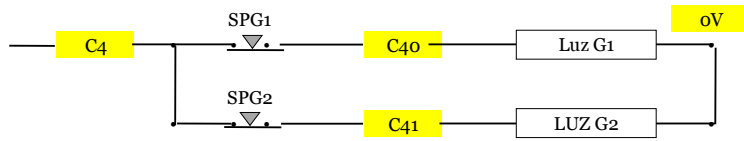

SPG1	Suiche en puerta G1	Luz CCM G1	Luz fluorescente
SPG2	Suiche en puerta G2	Luz CCM G2	Luz fluorescente

Por cada gabinete se instala una luz fluorescente para iluminar el gabinete, la luz se energiza por medio de un suiche instalado de tal manera que al abrir la puerta la luz se encienda y al cerrar la puerta la lámpara se desenergice.

**CONTROLADOR DE TEMPERATURA PARA EL GABINETE**

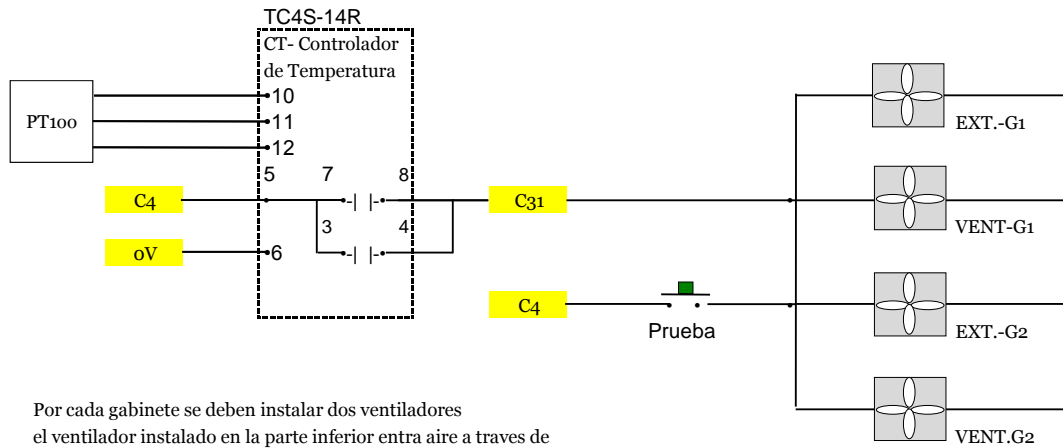

Por cada gabinete se deben instalar dos ventiladores el ventilador instalado en la parte inferior entra aire a través de un filtro (Tela no tejida)- El ventilador instalado en la parte superior saca aire no requiere filtro

DIAGRAMA PARA CONECTAR EL ANALIZAR DE REDES

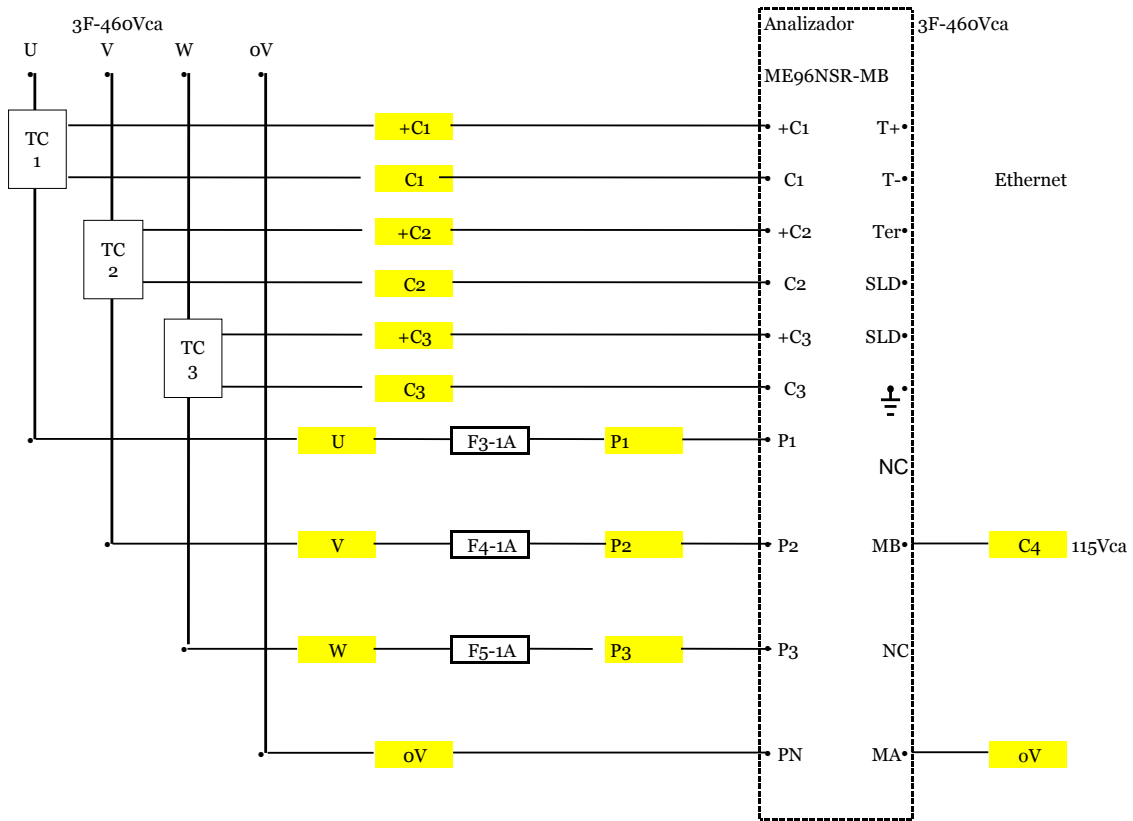

Notas

- 1 Los tres TC con Relación N/5.  
Para los tres TC se deben colar bornas para cortocircuito
- 3 El cable para modBus sera del tipo STP 3 hilos calibre 18

**M1** BC 15 TRANSPORTADOR DE BANDA 15

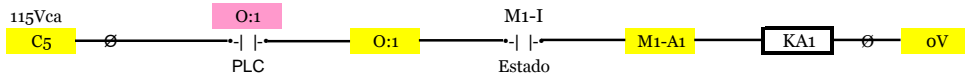
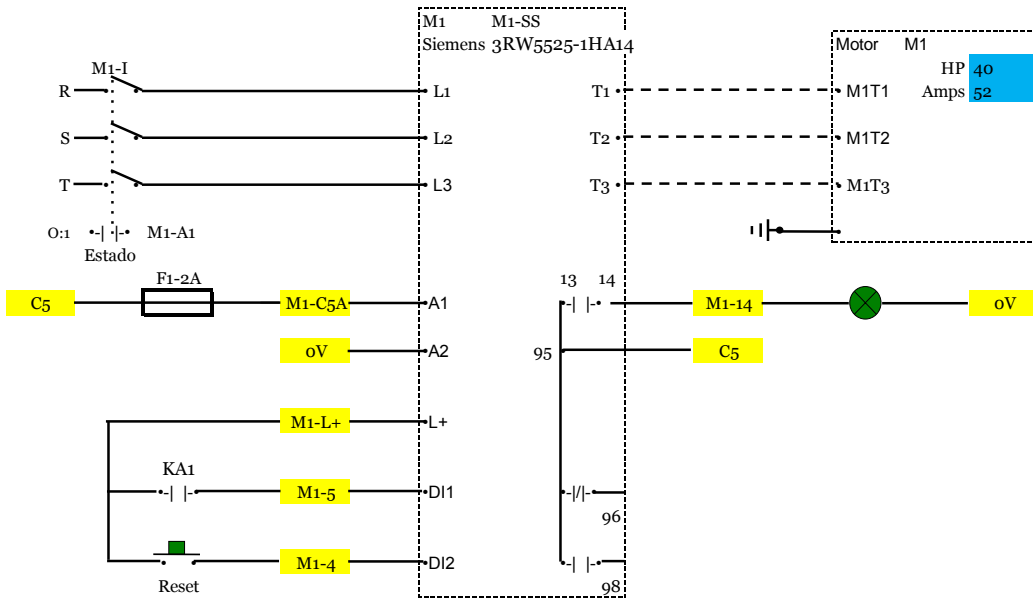

**M2** BC 16 TRANSPORTADOR DE BANDA 16

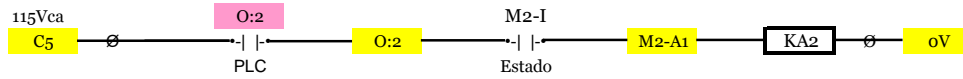
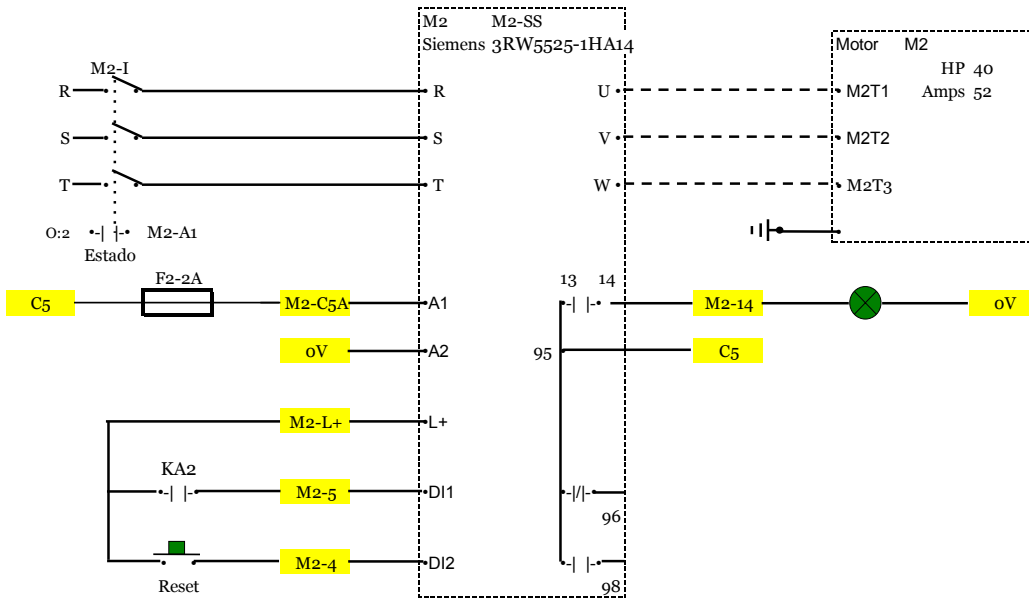

La confirmación se hace por medio del sensor de movimiento

**M3** TC 23 TRANSPORTADOR DE CADENA 23

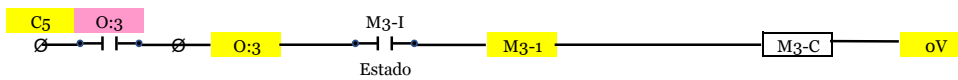
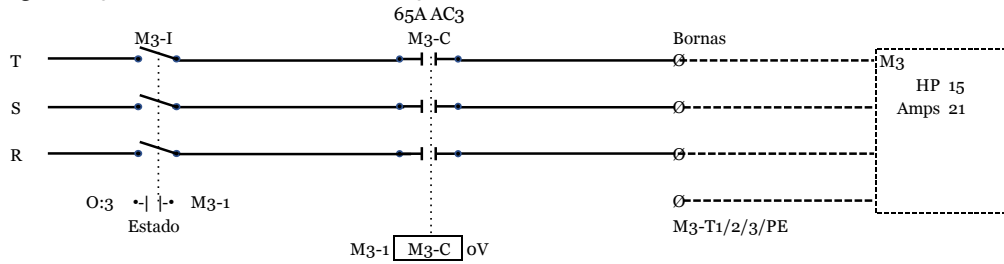

La confirmación se hace por medio del sensor de movimiento

**M4** EC 11 ELEVADOR DE CANGILONES 11

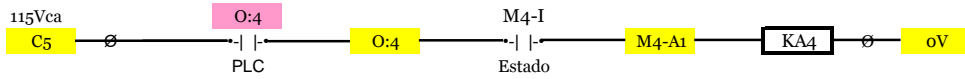
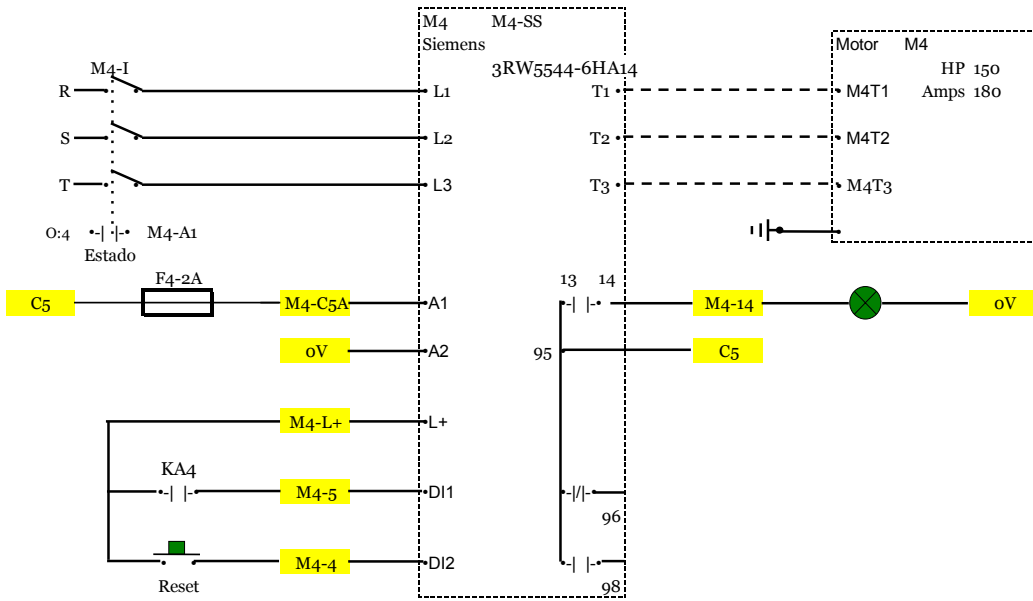



**M6** TRI-1 TRIPPER SILO 5

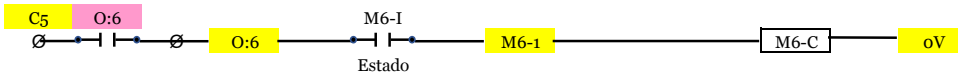
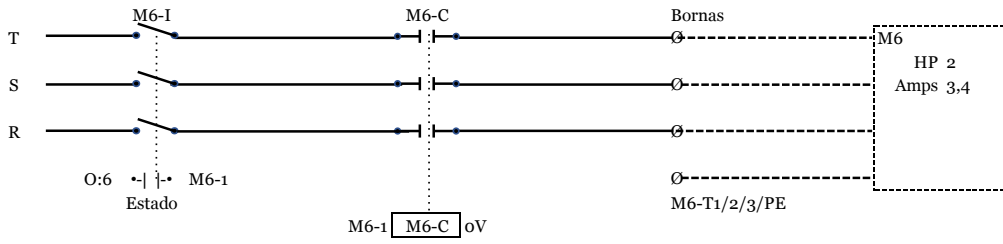

**M7** TRI-2 TRIPPER SILO 6

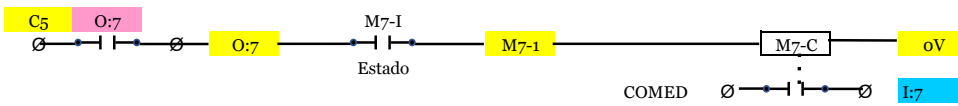
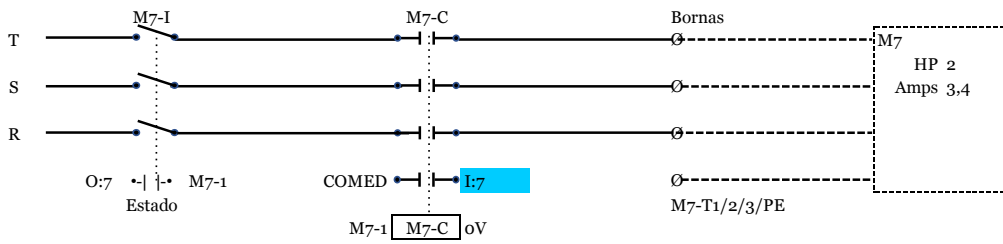

M8 TC 25 TRANSPORTADOR DE CADENA 25

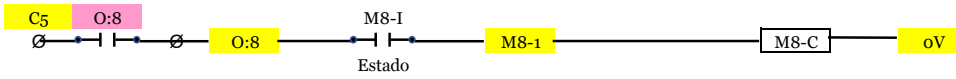
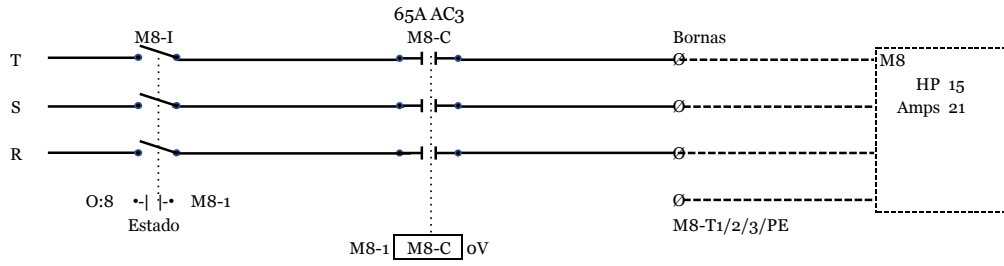

M9 TC26 TRANSPORTADOR DE CADENA 26

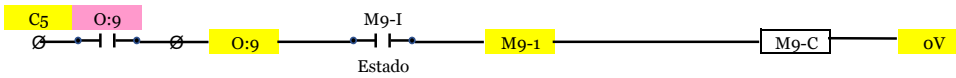
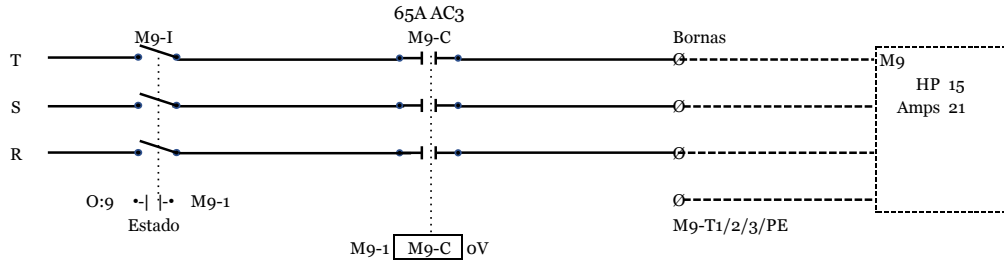

M10 TC 27 TRANSPORTADOR DE CADENA 27

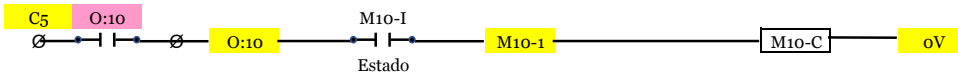
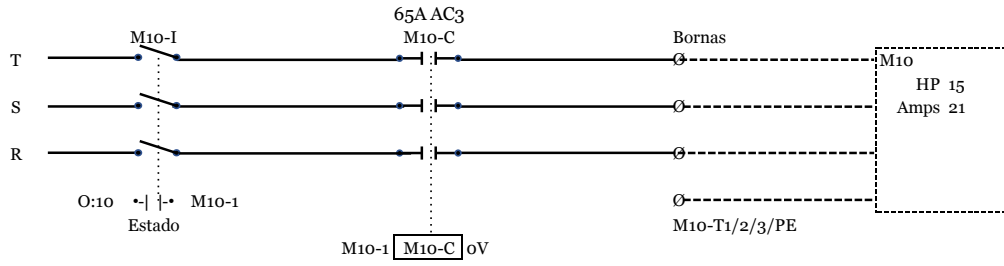

M11 TC 28 TRANSPORTADOR DE CADENA 28

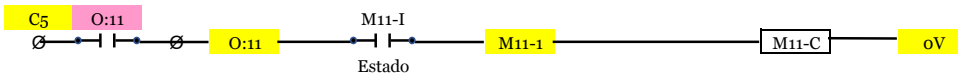
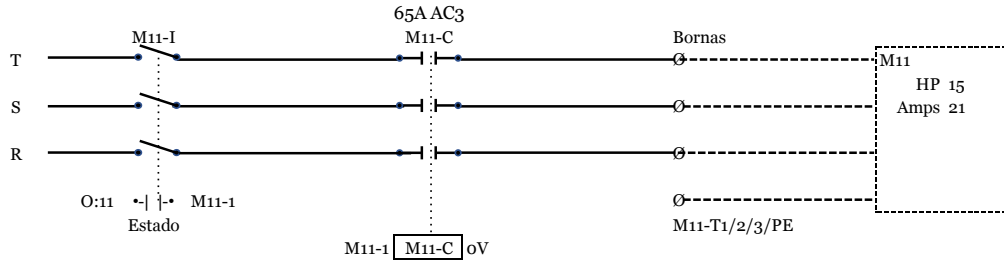

M12 TC 28 TRANSPORTADOR DE CADENA 28

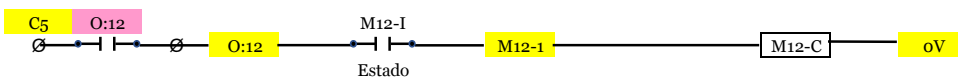
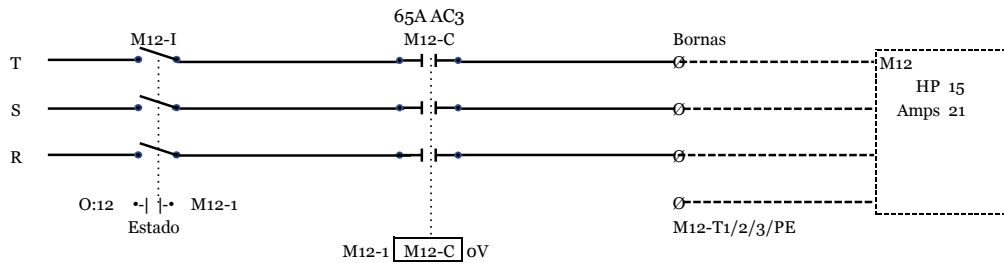

M13 TC 30 TRANSPORTADOR DE CADENA 30

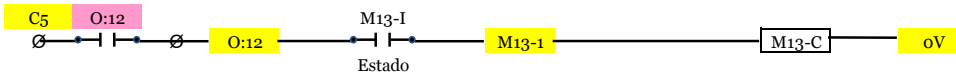
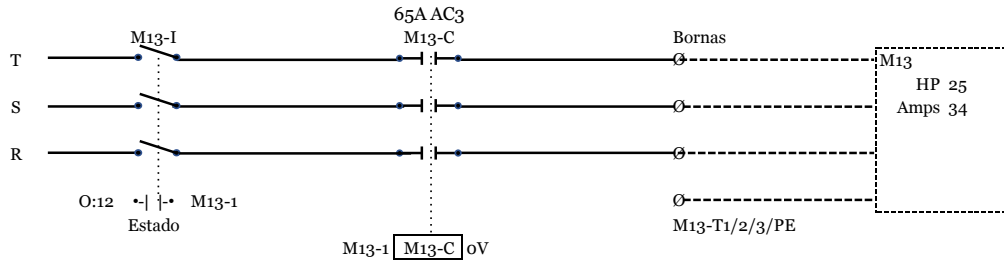

M14 TC 31 TRANSPORTADOR DE CADENA 31

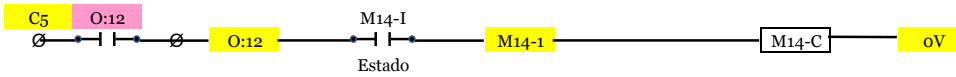
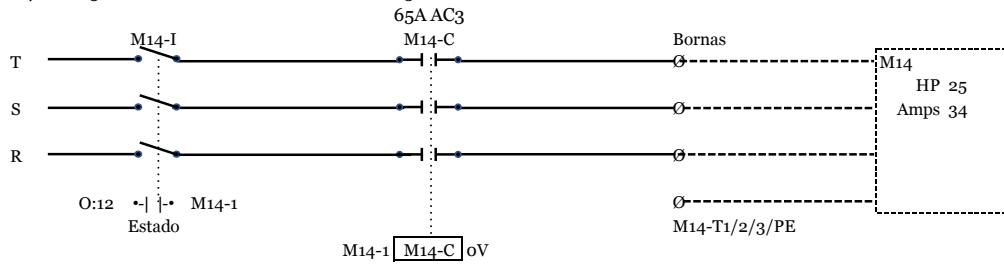

M15 EC 13 ELEVADOR DE CANGILONES 13

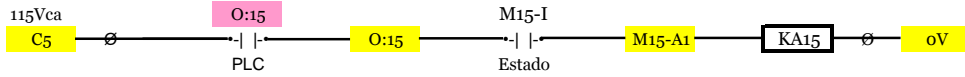
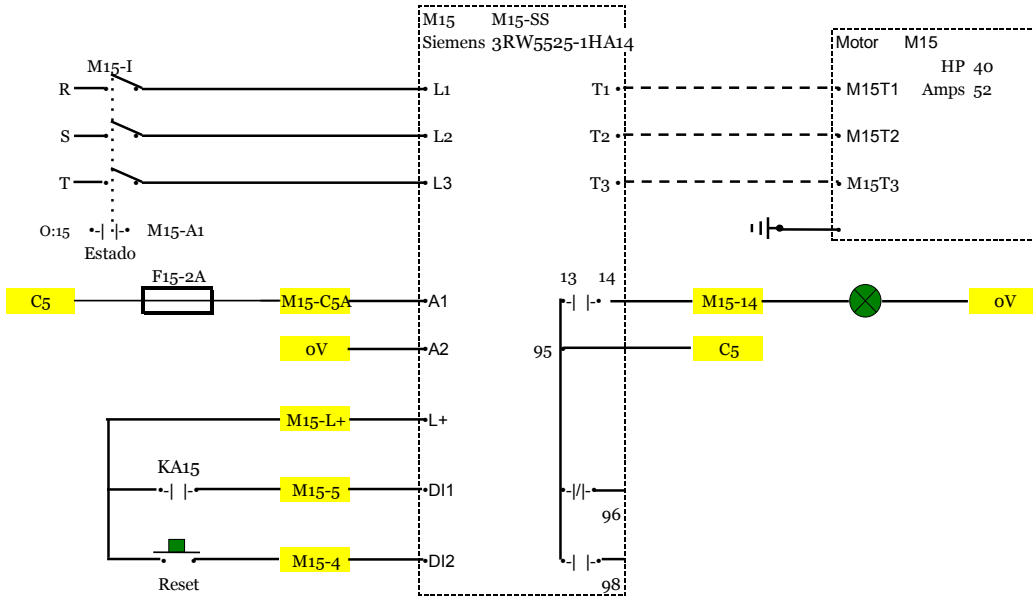

M16 EC 14 ELEVADOR DE CANGILONES 14

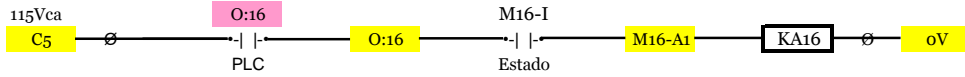
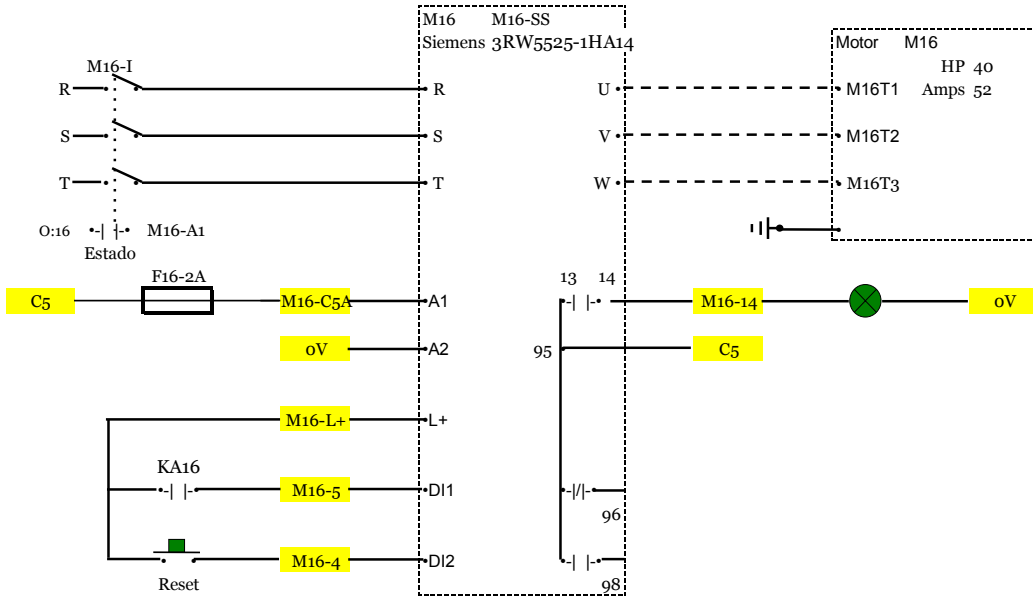

M17 TC 33 TRANSPORTADOR DE CADENA 33

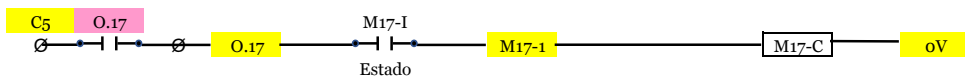
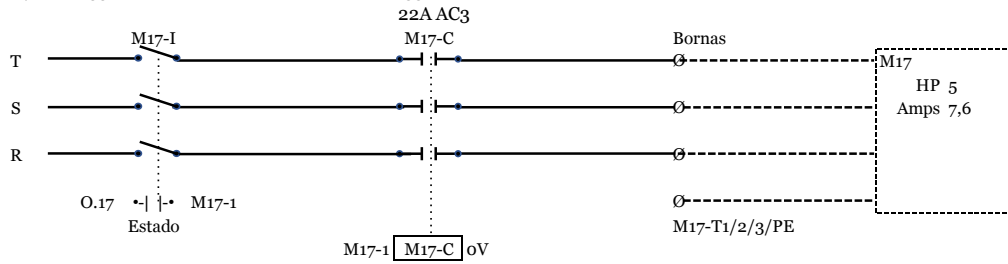

M18 TC 34 TRANSPORTADOR DE CADENA 34

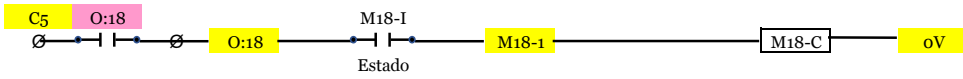
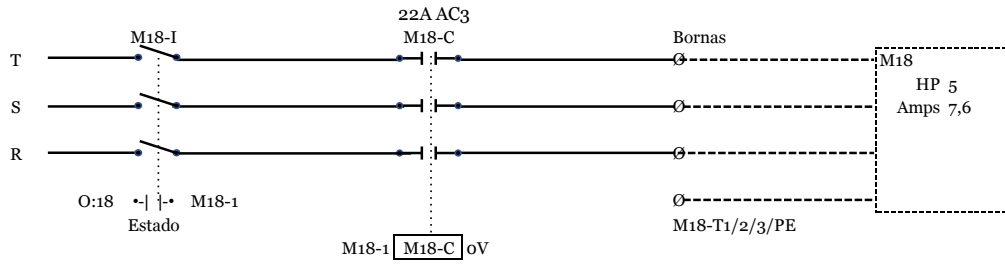

M19 TC 24 TRANSPORTADOR DE CADENA 24

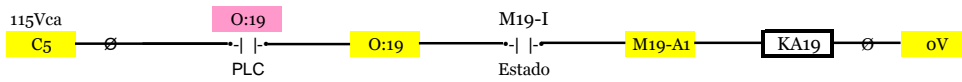
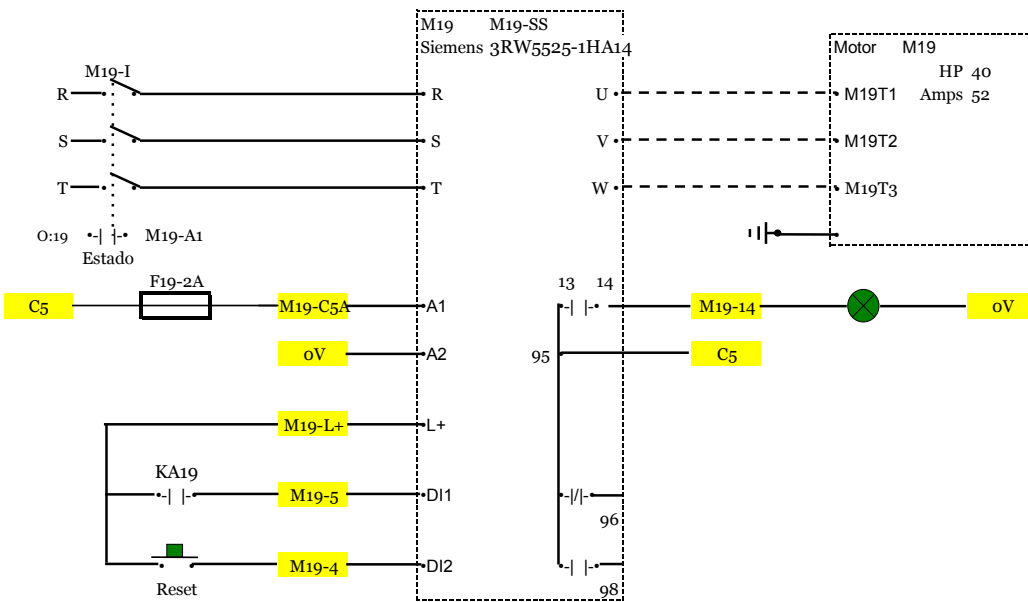

M20 TC 34 TRANSPORTADOR DE CADENA 34

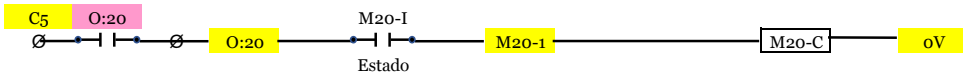
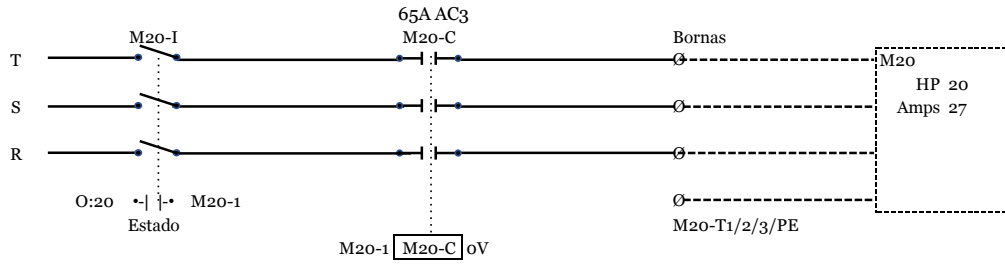

M21 EC 12 ELEVADOR DE CANGILONES 12

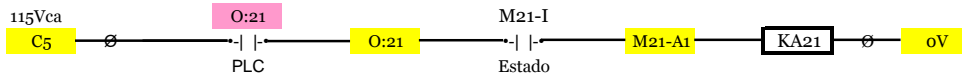
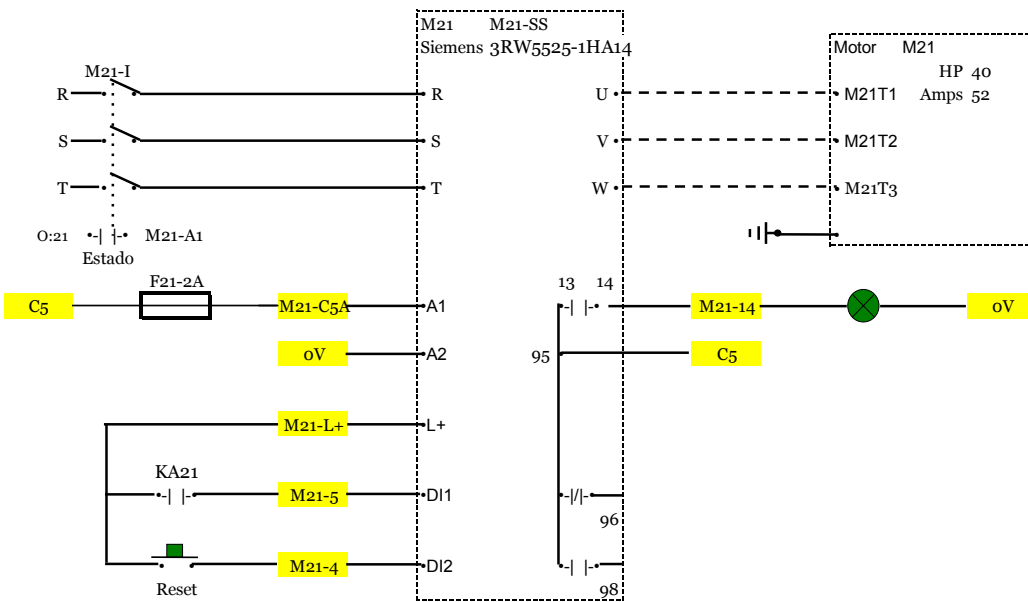

M22 COMP COMPRESOR

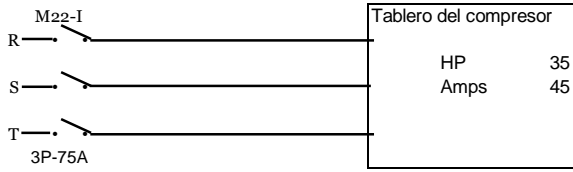

El compresor trae su propio tablero

# Motor	CODIG	EQUIPO	HP	Amp-P	Amps	Kva	Amps SS	Ref.SS-Siemens	Int-Siemens
M1	BC 15	TRANSPORTADOR DE BANDA 15	40,0	52,0	59,8	48	66	3RW5525-1HA14	84
M2	BC 16	TRANSPORTADOR DE BANDA 16	40,0	52,0	59,8	48	66	3RW5525-1HA14	84
M3	TC 23	TRANSPORTADOR DE CADENA 23	15,0	21,0	24,2	19	D	65A AC3	20/25
M4	EC 11	ELEVADOR DE CANGILONES 11	150,0	180,0	207,0	165	228	3RW5544-6HA14	319
M5	BC 17	TRANSPORTADOR DE BANDA 17	100,0	124,0	142,6	113	157	3RW5535-6HA14	220
M6	TRI-1	TRIPPER SILO 5	2,0	3,4	3,9	3	D	22A AC3	2.5/4
M7	TRI-2	TRIPPER SILO 6	2,0	3,4	3,9	3	D	22A AC3	2.5/4
M8	TC 25	TRANSPORTADOR DE CADENA 25	15,0	21,0	24,2	19	D	65A AC3	37
M9	TC26	TRANSPORTADOR DE CADENA 26	15,0	21,0	24,2	19	D	65A AC3	37
M10	TC 27	TRANSPORTADOR DE CADENA 27	15,0	21,0	24,2	19	D	65A AC3	37
M11	TC 28	TRANSPORTADOR DE CADENA 28	15,0	21,0	24,2	19	D	65A AC3	37
M12	TC 29	TRANSPORTADOR DE CADENA 29	15,0	21,0	24,2	19	D	65A AC3	37
M13	TC 30	TRANSPORTADOR DE CADENA 30	25,0	34,0	39,1	31	43	3RW5517-1HA14	60
M14	TC 31	TRANSPORTADOR DE CADENA 31	25,0	34,0	39,1	31	43	3RW5517-1HA14	60
M15	EC 13	ELEVADOR DE CANGILONES 13	40,0	52,0	59,8	48	66	3RW5525-1HA14	92
M16	EC 14	ELEVADOR DE CANGILONES 14	40,0	52,0	59,8	48	66	3RW5525-1HA14	92
M17	TC 33	TRANSPORTADOR DE CADENA 33	7,5	11,0	12,7	10	D	22A AC3	11
M18	TC 34	TRANSPORTADOR DE CADENA 34	7,5	11,0	12,7	10	D	22A AC3	11
M19	TC 24	TRANSPORTADOR DE CADENA 24	40,0	52,0	59,8	48	66	3RW5525-1HA14	92
M20	TC 32	TRANSPORTADOR DE CADENA 32	20,0	27,0	31,1	25	D	65A AC3	27
M21	EC 12	ELEVADOR DE CANGILONES 12	40,0	52,0	59,8	48	66	3RW5525-1HA14	92
M22	COMP	COMPRESOR Tiene su propio tablero	30,0	40,0	46,0	37	51		

CCM-6

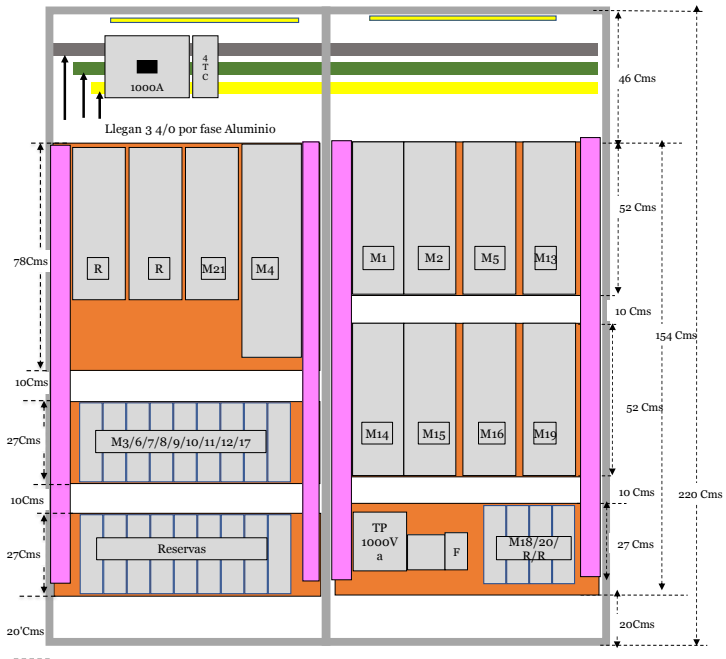

Espacio disponible

Dimensiones en metros

	G1	G2	Total	m2	Kg
Altura	2,2	2,2	2,2	18,74	287
Ancho	1,0	1,0	2,0		
Prof.	0,6	0,6	0,6		
Lámina	14	14			
Color	RAL 7032				
IP	60				

La Fuente sera marca WEIDMULLER 40A

Los cables que van a los motores se sacan directamente de la salida de los arrancadores

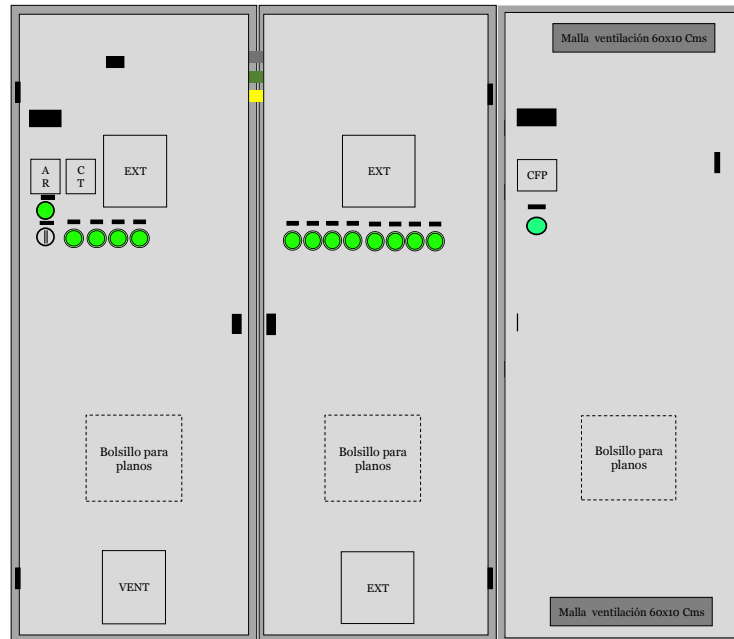

Atención: Los ventiladores extractores (Superiores) de las dos celdas deben montarse como se indica

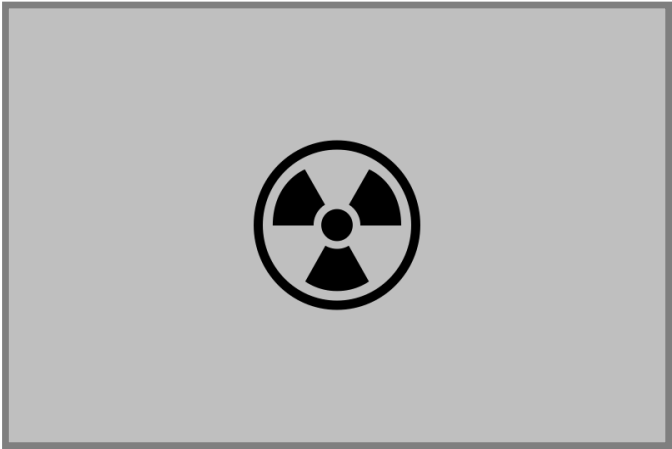
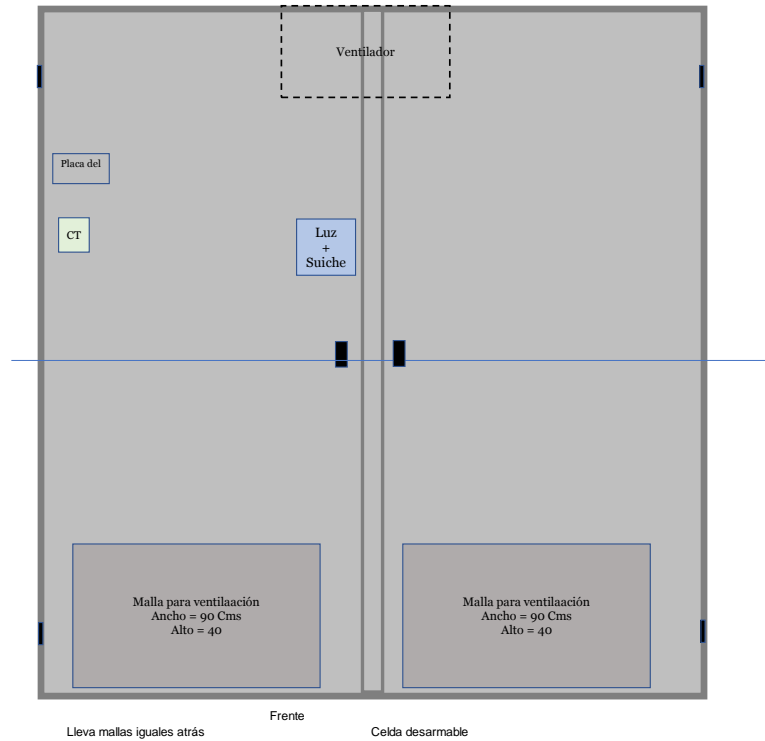

Parte superior

El ventilador Tiene que ir centrado  
Saca aire de la celda

Dimensiones en metros

	m2	Kilos
Altura	2,4	24,869
Ancho	2,4	380,49
Prof.	1,54	
Lámina		
Color		
IP		